

Spin Detection and Manipulation with SPM

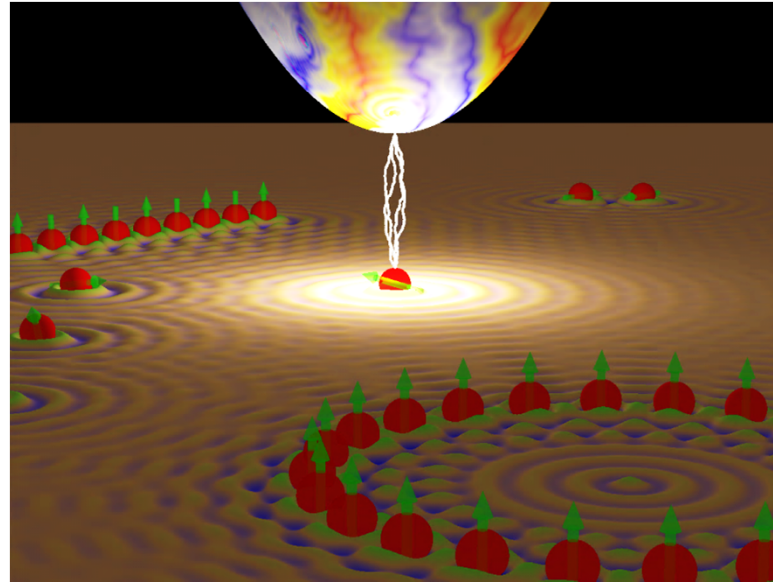

基于扫描探针显微镜的分析方法

Single Spin Detection with SPM

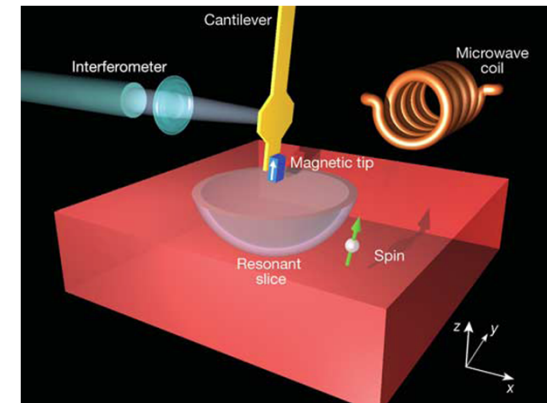
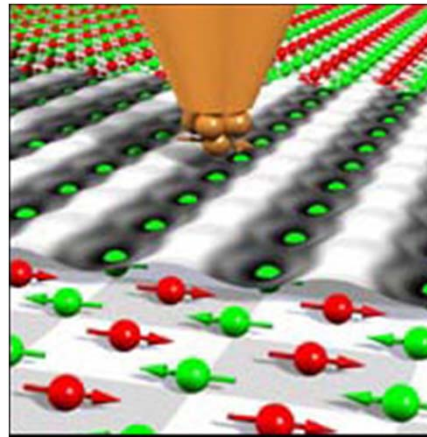
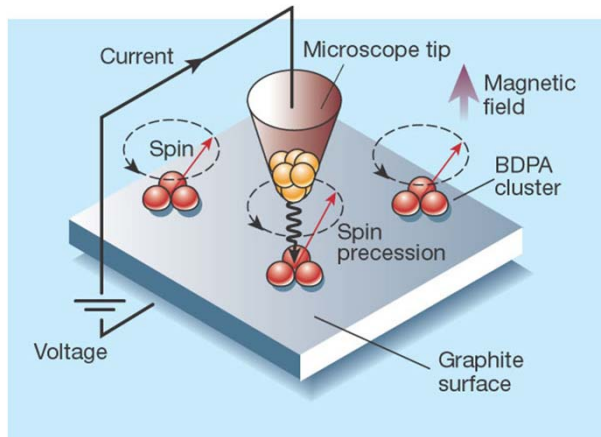
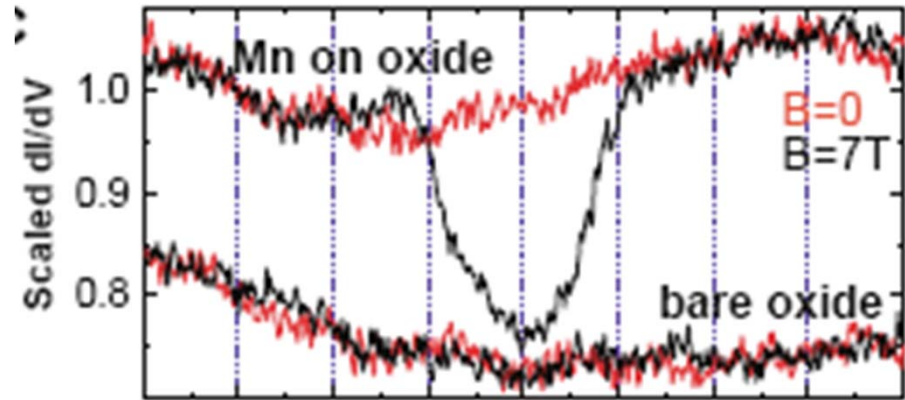
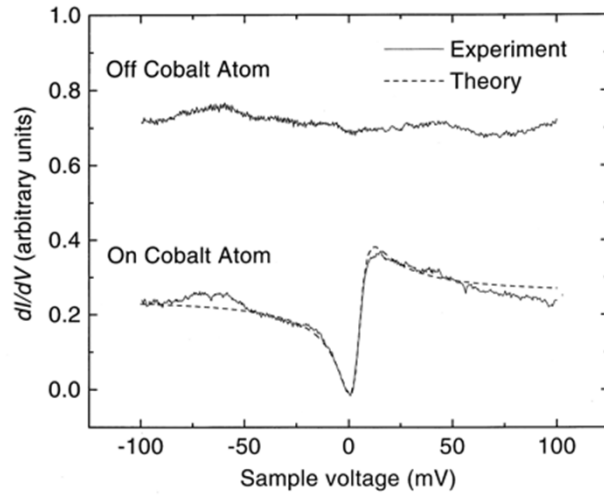

Nature 430, 329 (2004).

Electron Spin Resonance STM

Spin State in B field

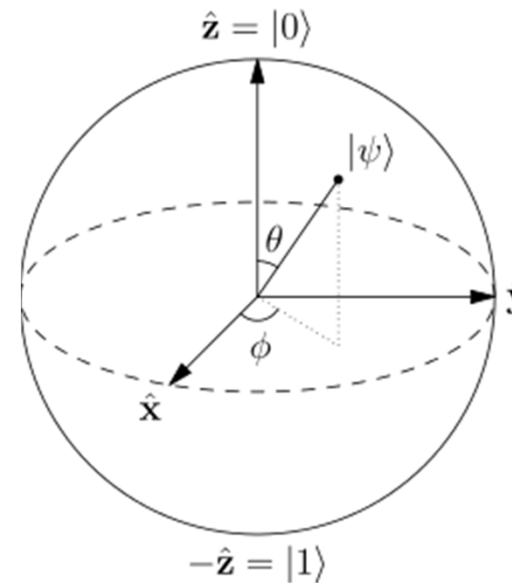
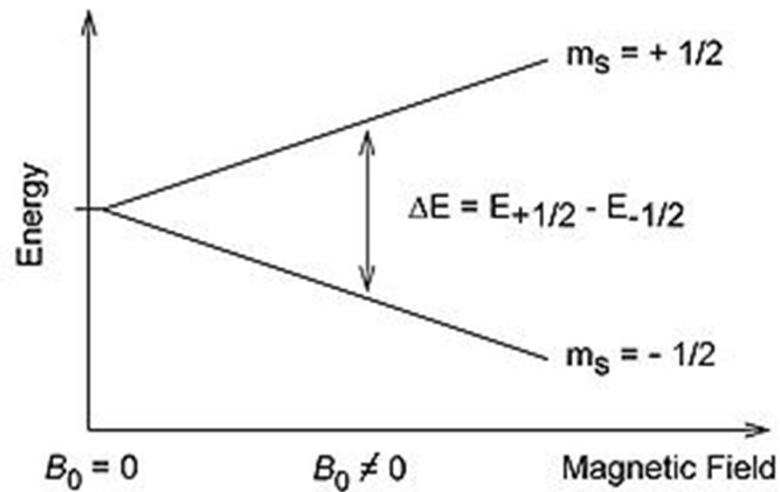

$$\omega_L = \frac{g\mu_B B}{\hbar} = \frac{geB}{2m}$$

$\sim 2.8 \text{ MHz / Gauss}$

$$|\psi\rangle = \cos\left(\frac{\theta}{2}\right) |0\rangle + e^{i\phi} \sin\left(\frac{\theta}{2}\right) |1\rangle$$

Electron Spin Resonance STM

Microwave absorption spectra

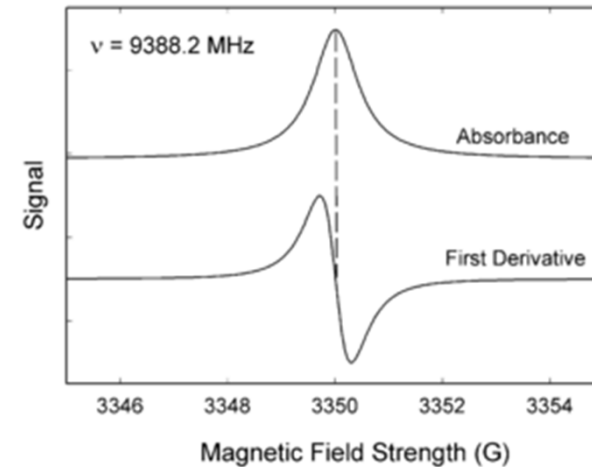
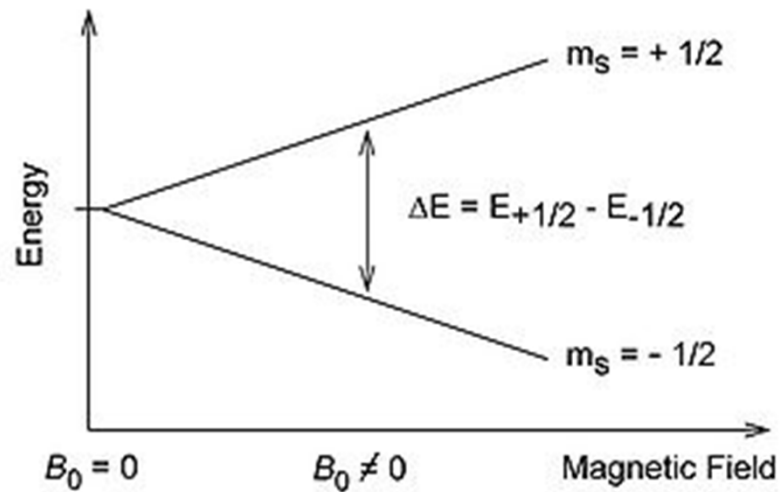

$$\omega_L = \frac{g\mu_B B}{\hbar} = \frac{geB}{2m}$$

~ 2.8 MHz / Gauss

Electron Spin Resonance STM

Use of ESR

g因子：局域化学环境
频谱线宽：退相干时间

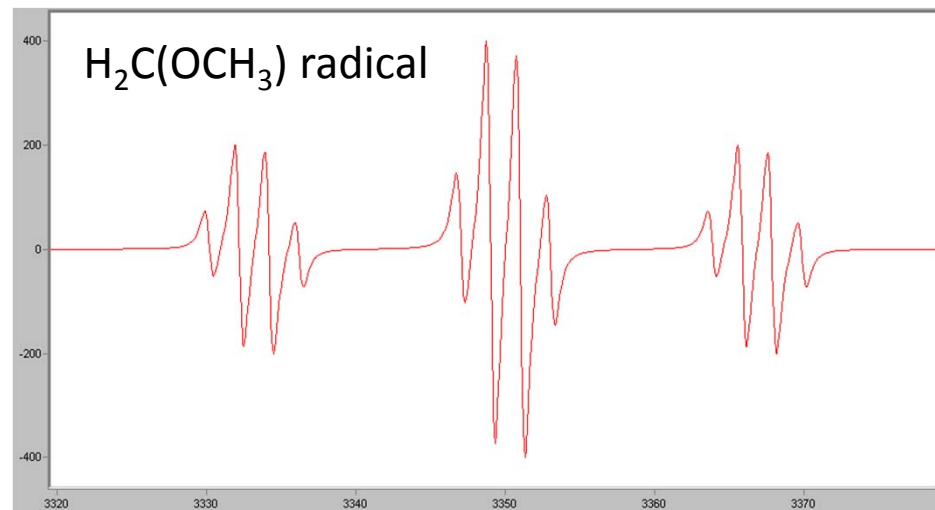
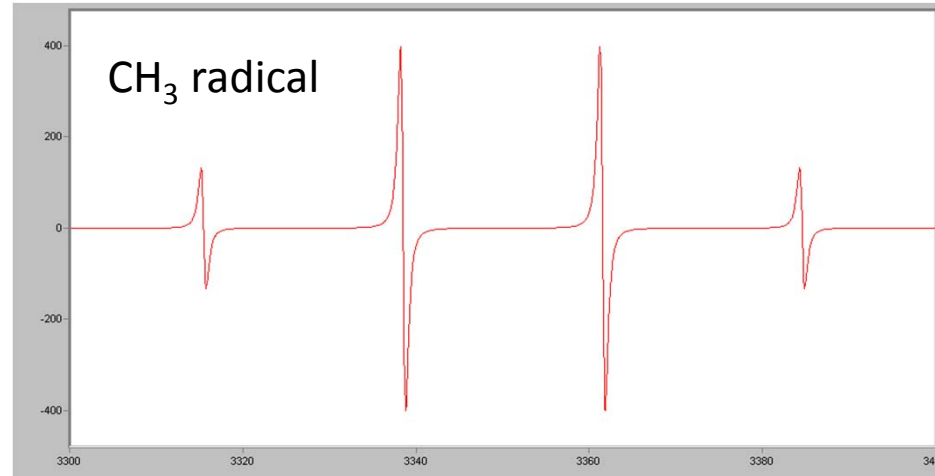

Electron Spin Resonance STM

Spin Echo: Measure T2

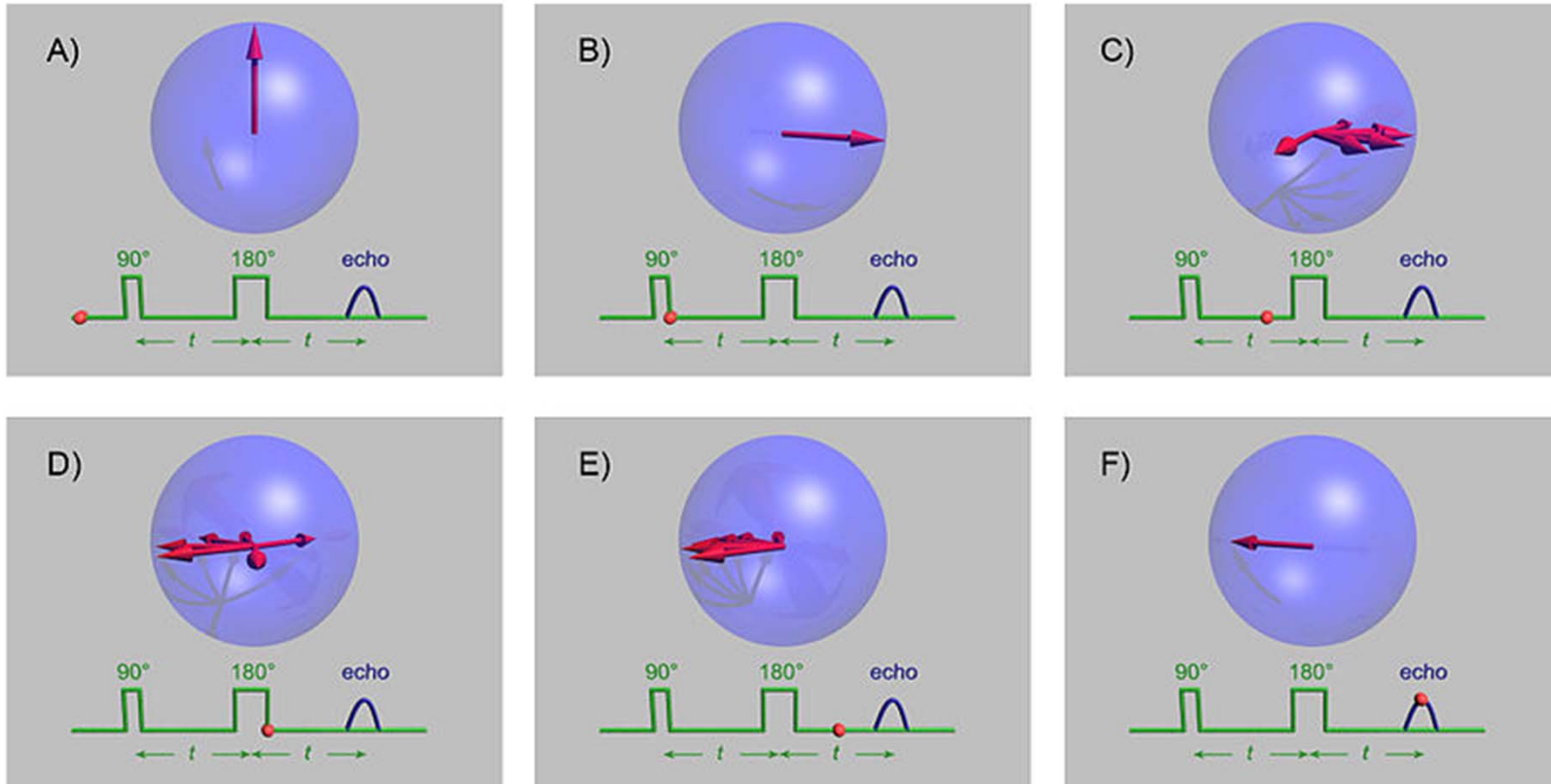

Electron Spin Resonance STM

Basic Instrument Setup

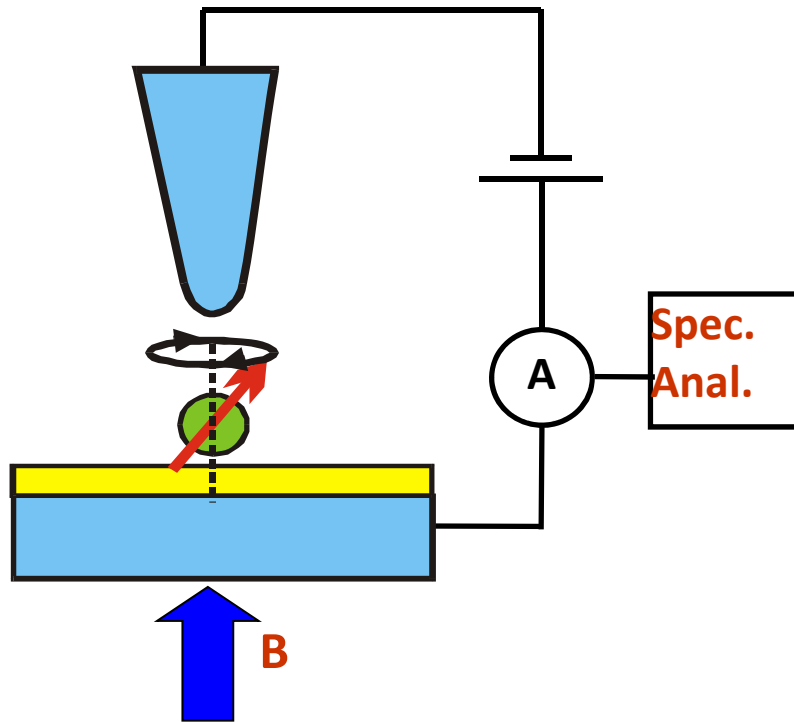

$$\omega_L = \frac{g\mu_B B}{\hbar} = \frac{geB}{2m}$$

~ 2.8 MHz / Gauss

g因子：局域化学环境
频谱线宽：退相干时间

(传统ESR: $> 10^{10}$ 自旋中心)

Electron Spin Resonance STM

Basic Instrument Setup

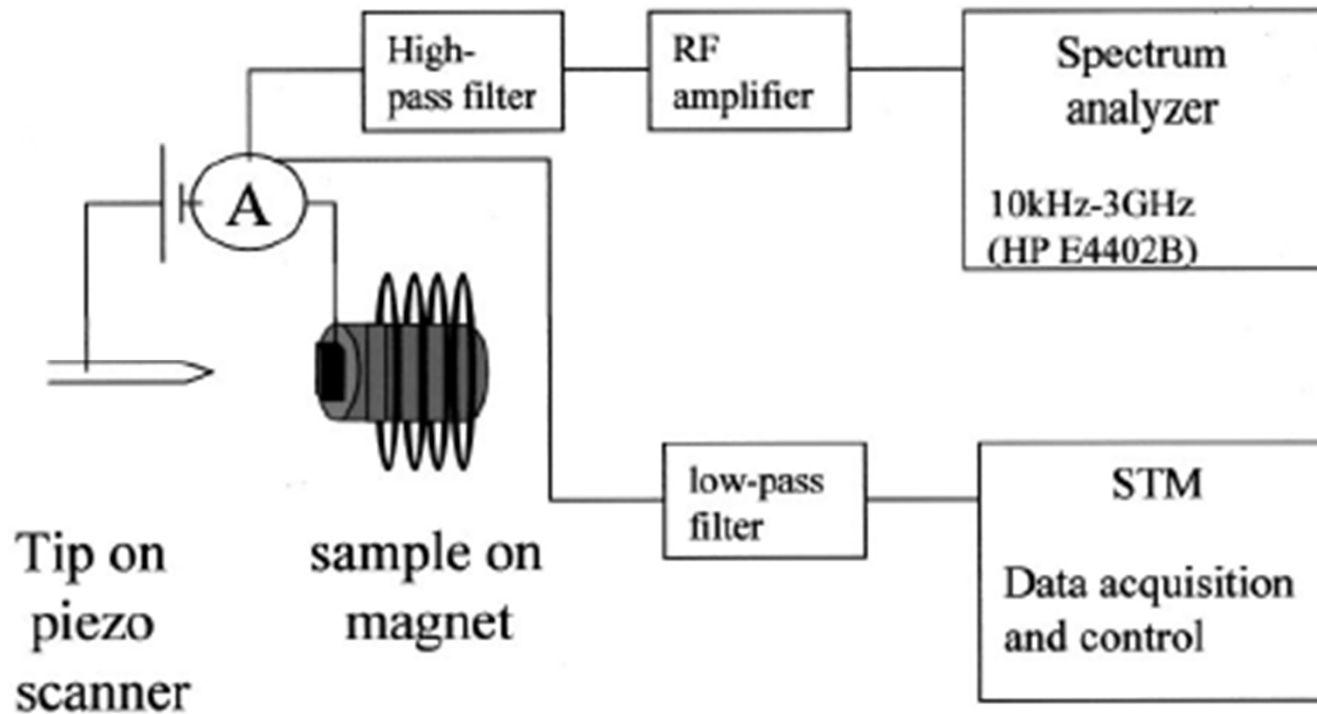

Appl. Phys. Lett. 80, 458(2002)

Electron Spin Resonance STM

Basic Instrument Setup

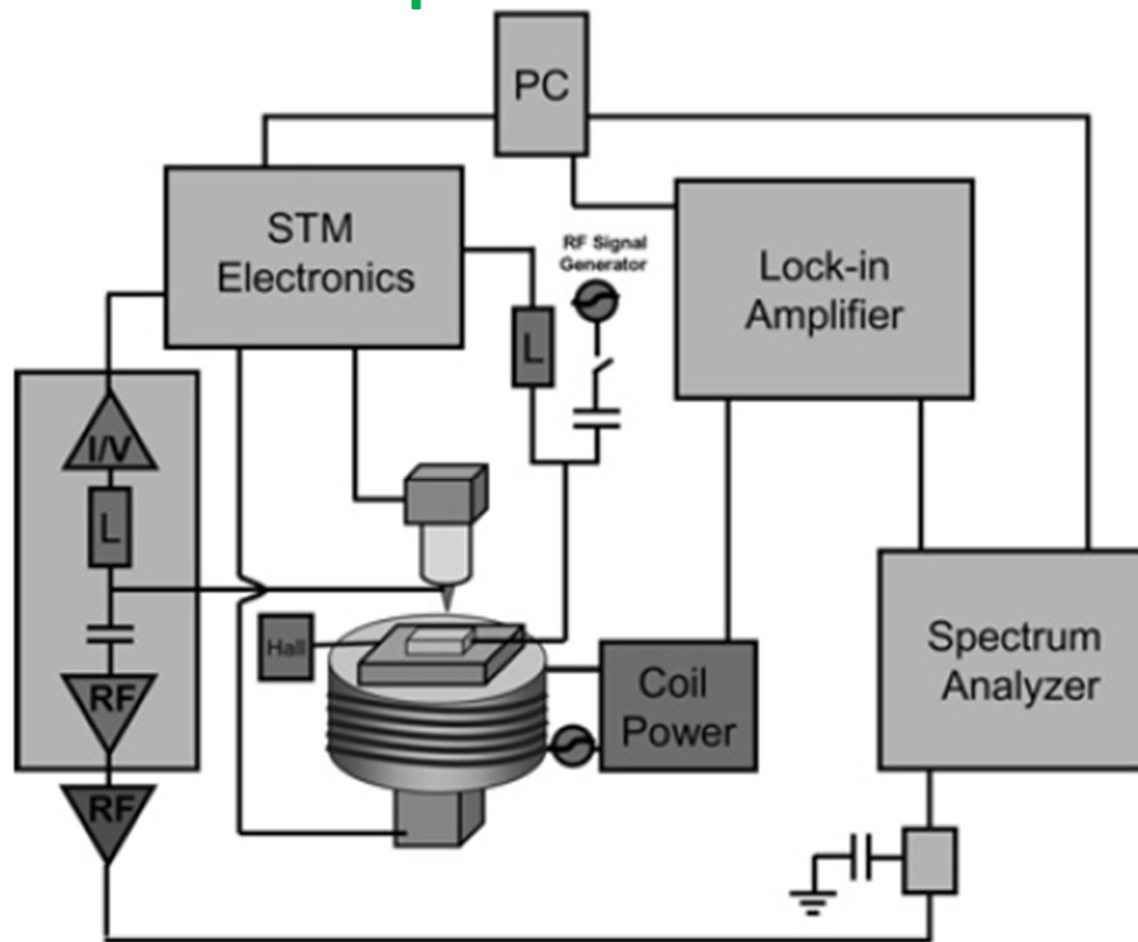

Inorganica Chimica Acta 361, 4089(2008)

Electron Spin Resonance STM

Basic Instrument Setup

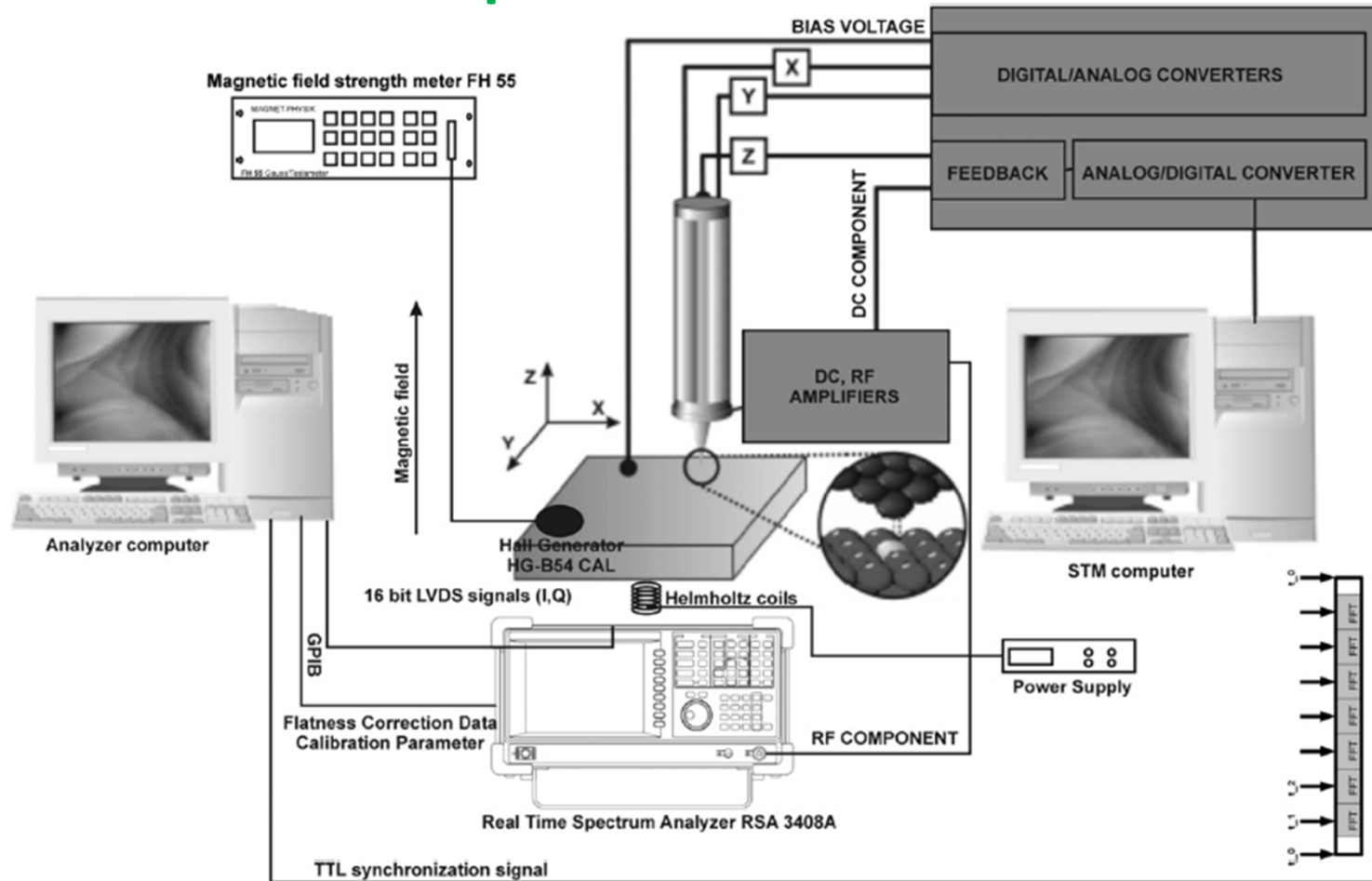

Measurement 43, 195(2010)

Electron Spin Resonance STM

RF preamplifier

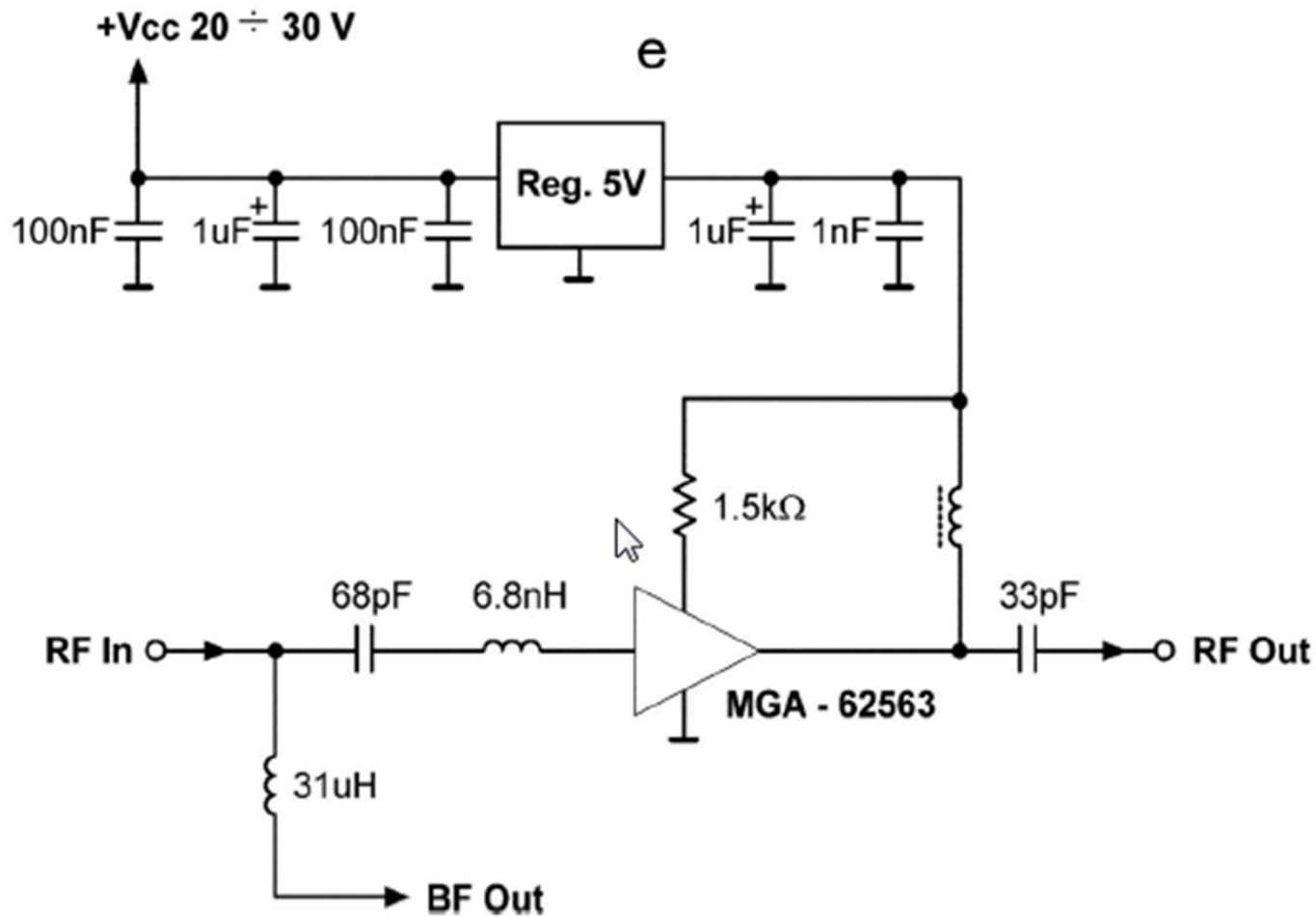

Electron Spin Resonance STM

RF preamplifier

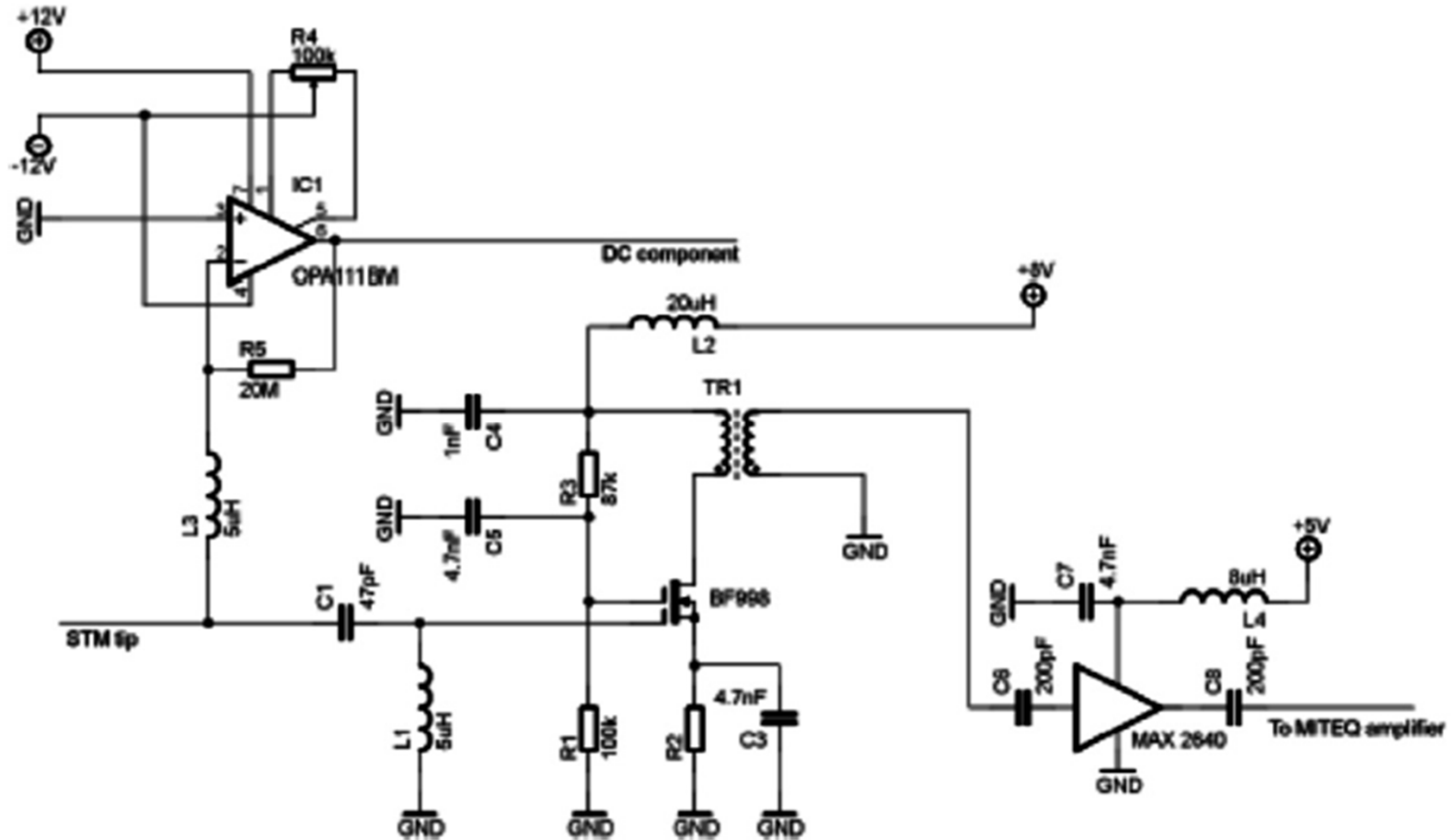

Measurement 43, 195(2010)

Electron Spin Resonance STM

Phase Sensitive Detection

$$F(t) = A \{ J_0(m_\omega) \sin(\omega_c t) + J_1(m_\omega) [\sin(\omega_c + \omega_m) t - \sin(\omega_c - \omega_m) t] + J_2(m_\omega) [\sin(\omega_c + 2\omega_m) t + \sin(\omega_c - 2\omega_m) t] + \dots \},$$

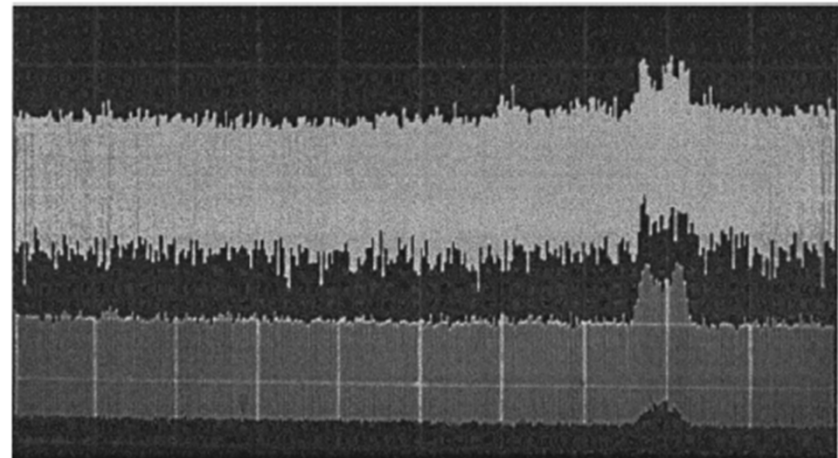
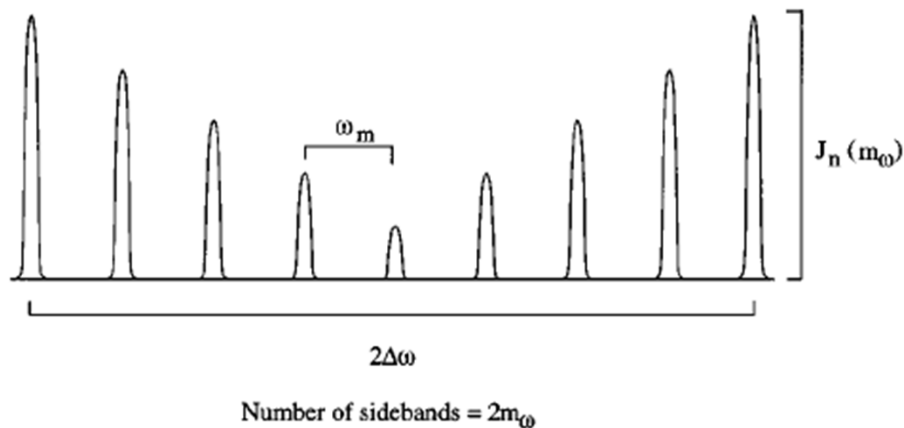

J. of Mag. Res. 126, 133(1997)

Electron Spin Resonance STM

Phase Sensitive Detection

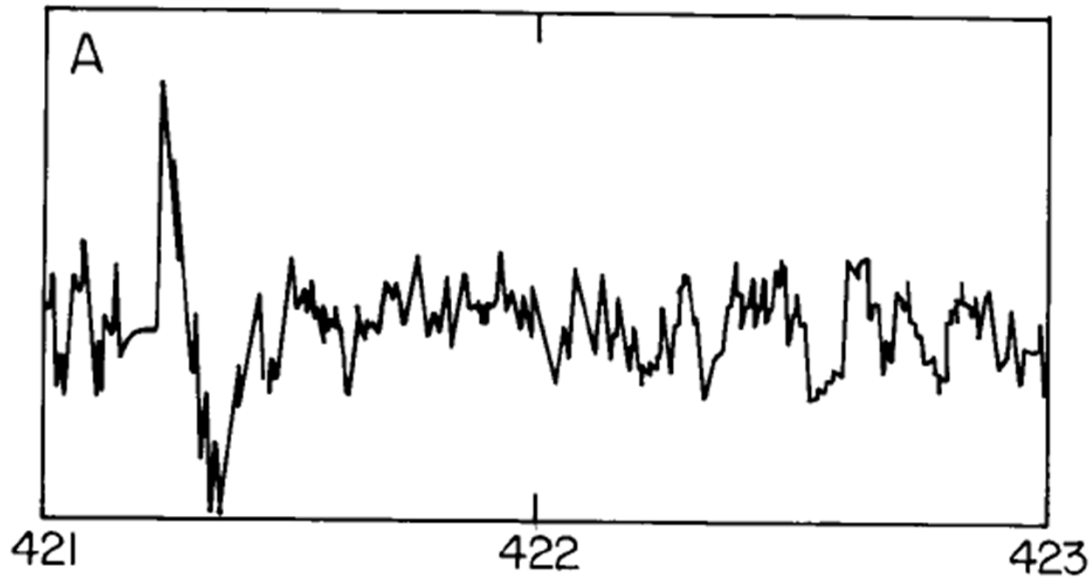
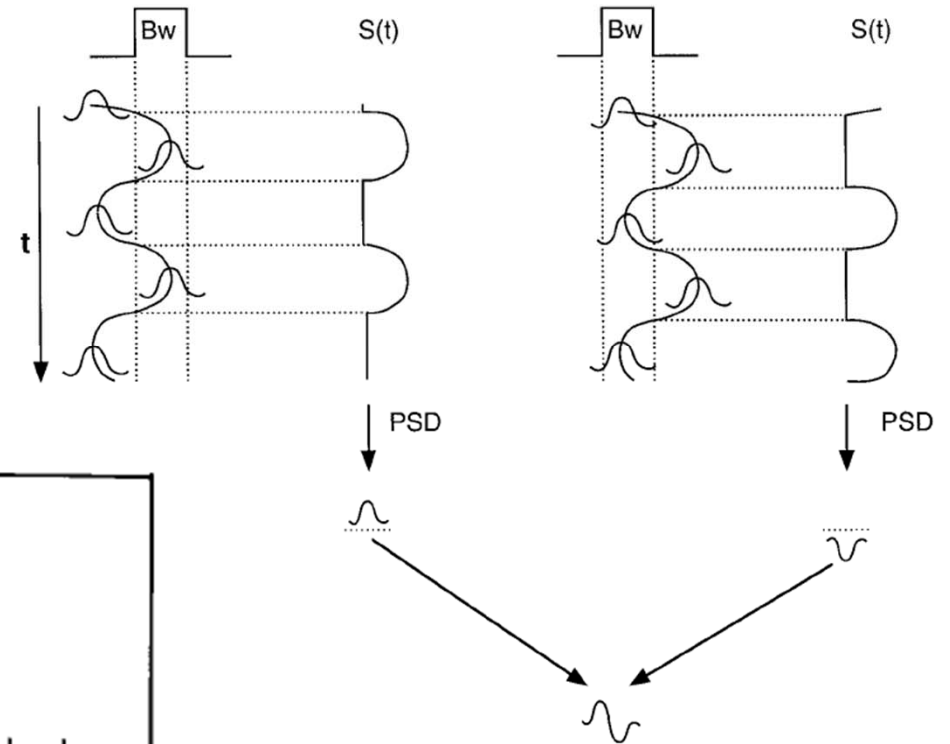

J. of Mag. Res. 126, 133(1997)

Electron Spin Resonance STM

History: First Paper by Manassen

VOLUME 62, NUMBER 21

PHYSICAL REVIEW LETTERS

22 MAY 1989

Direct Observation of the Precession of Individual Paramagnetic Spins on Oxidized Silicon Surfaces

Y. Manassen, R. J. Hamers, J. E. Demuth, and A. J. Castellano, Jr.

IBM Research Division, T. J. Watson Research Center, Yorktown Heights, New York 10598

(Received 12 December 1988)

The precession of individual spins on partially oxidized Si(111) surfaces has been detected using a scanning tunneling microscope. The spin precession in a constant magnetic field induces a modulation in the tunneling current at the Larmor frequency. This radio-frequency signal is shown to be localized over distances less than 10 Å and follows the expected magnetic field dependence.

Electron Spin Resonance STM

History

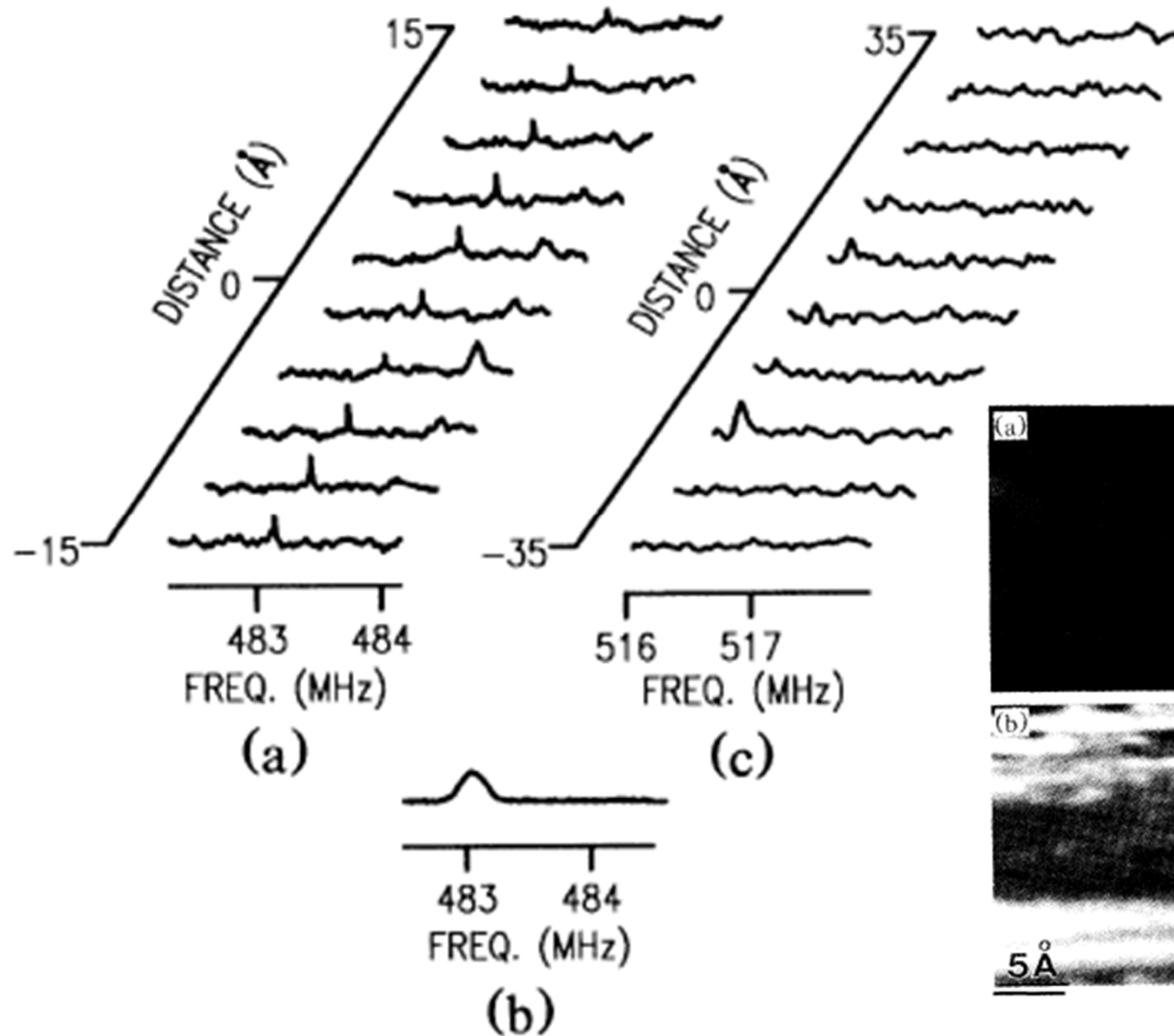

Electron Spin Resonance STM

History

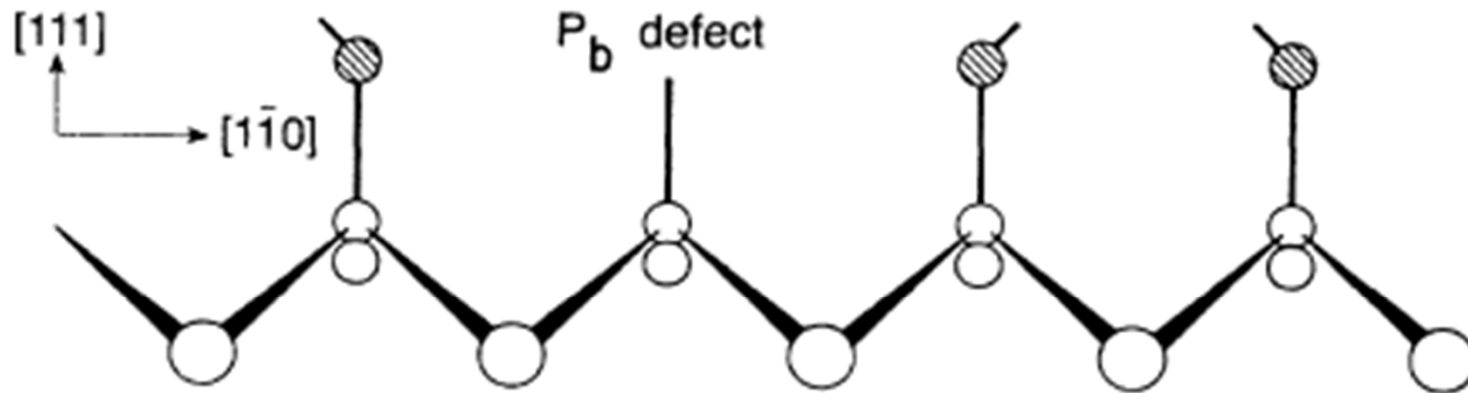

○ silicon
◐ oxygen

Partially Oxidized Silicon Surface

Electron Spin Resonance STM

History

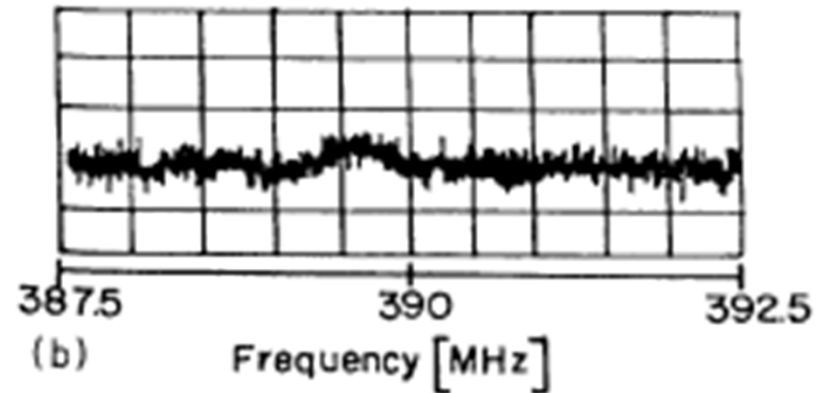
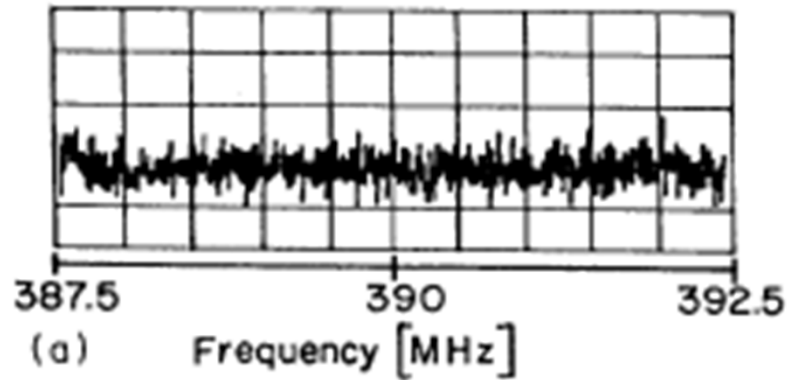

(a),(b): 139G
(c): 157G

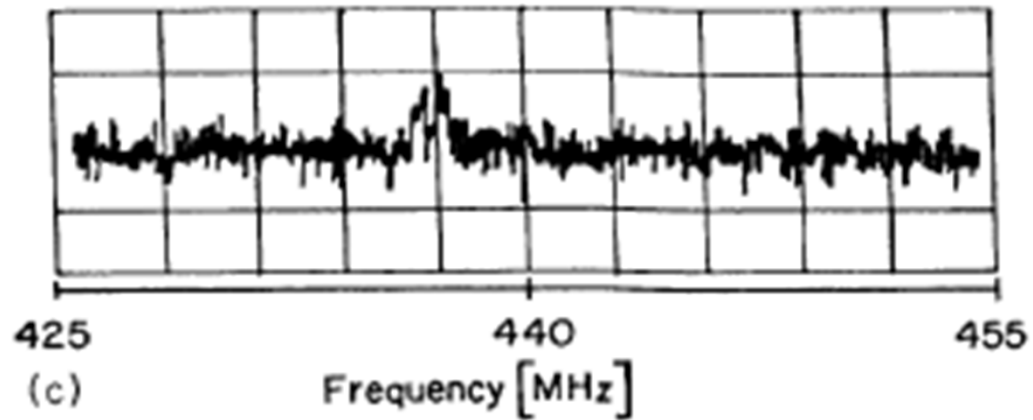

PRB 48, 4887(1993)

Electron Spin Resonance STM

History

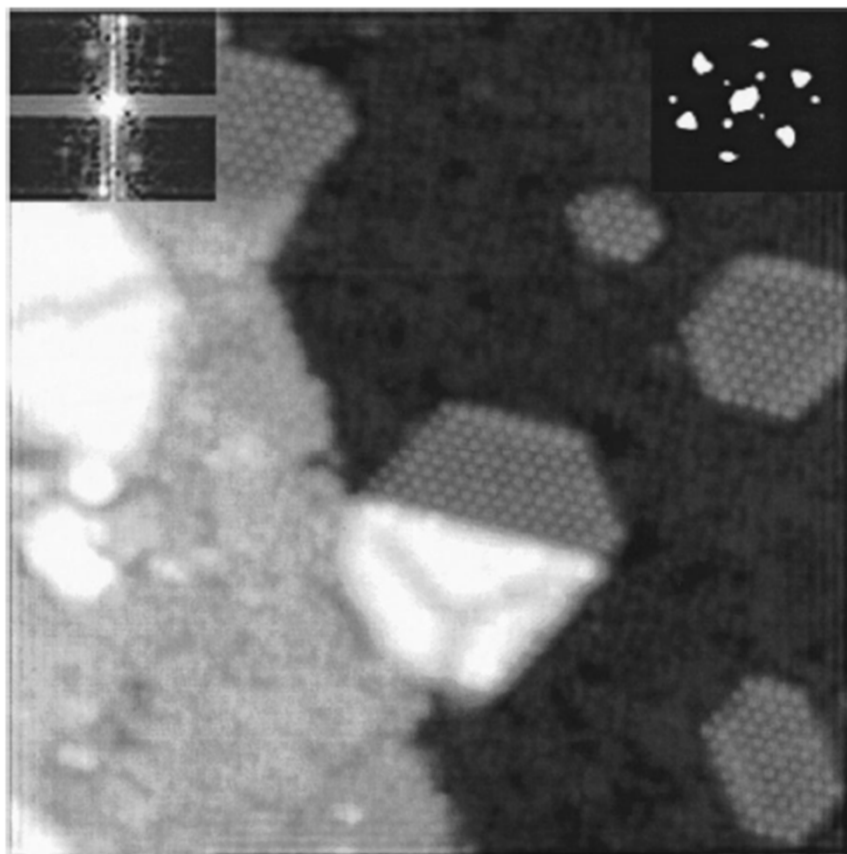

Fe atoms on Silicon

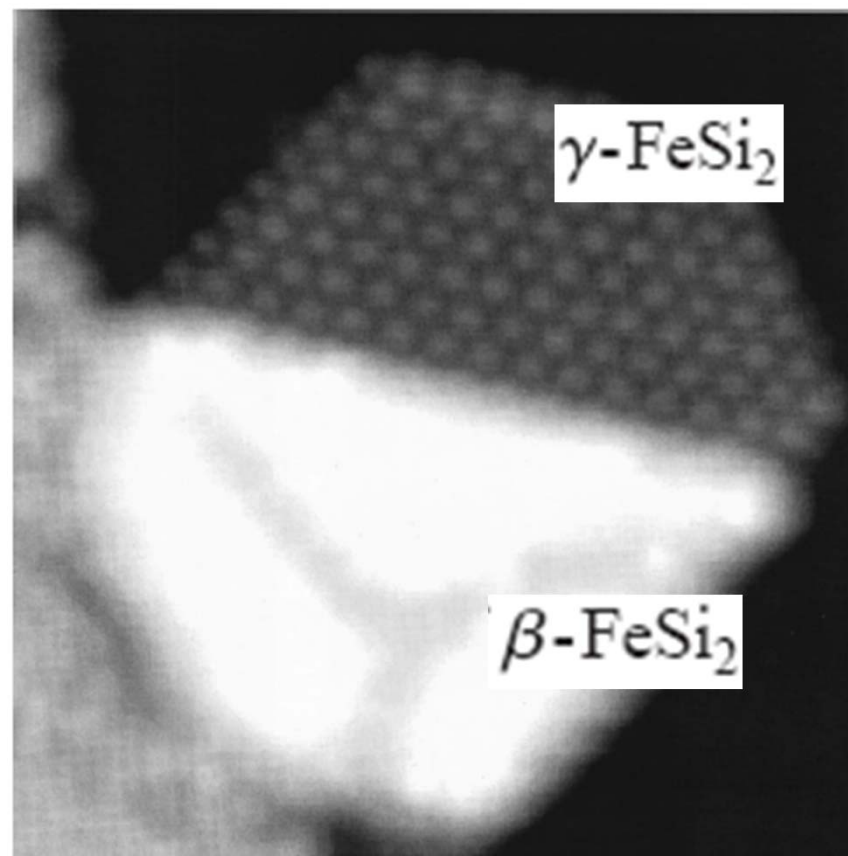

PRB 61, 16223(2000)

Electron Spin Resonance STM

History

Electronic spin detection in molecules using scanning-tunneling-microscopy-assisted electron-spin resonance

C. Durkan^{a)} and M. E. Welland

Nanoscale Science Laboratory, Department of Engineering, University of Cambridge, Trumpington Street, Cambridge CB2 1PZ, United Kingdom

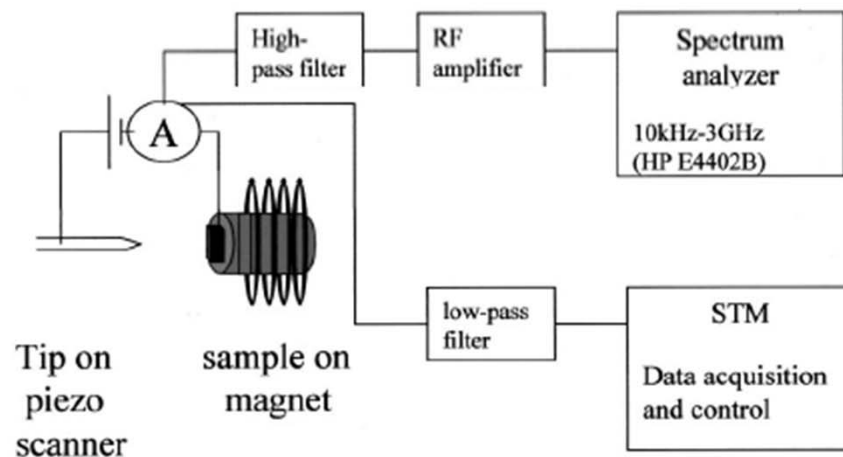
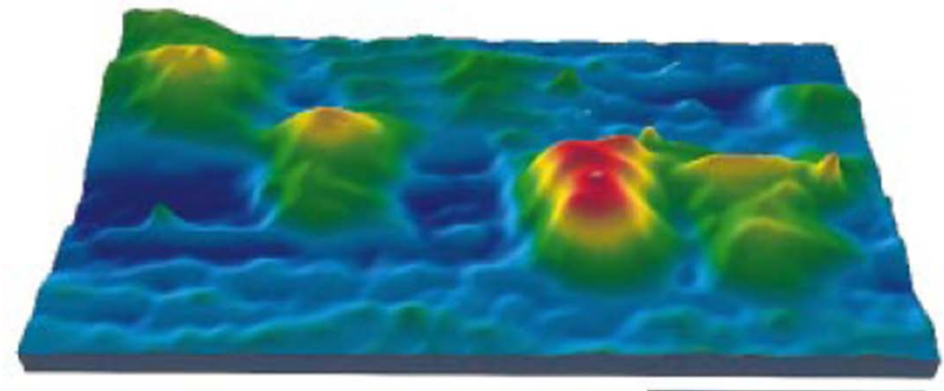

FIG. 1. Schematic of the electronics used in STM-ESR.



BDPA on Graphite

10 nm

APL, 80, 458(2002)

Electron Spin Resonance STM

History

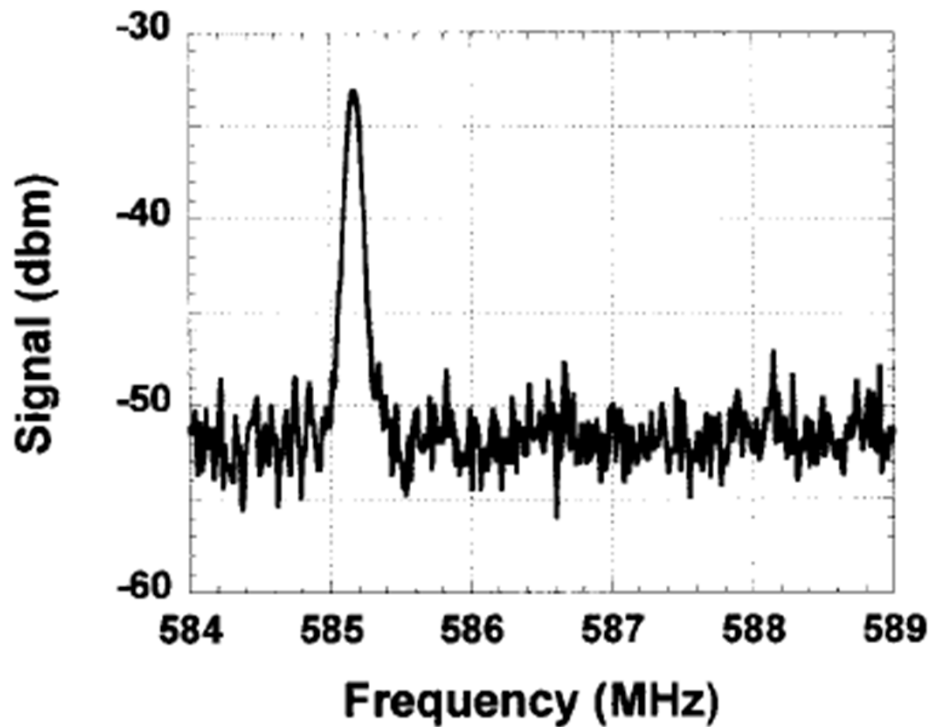

APL, 80, 458(2002)

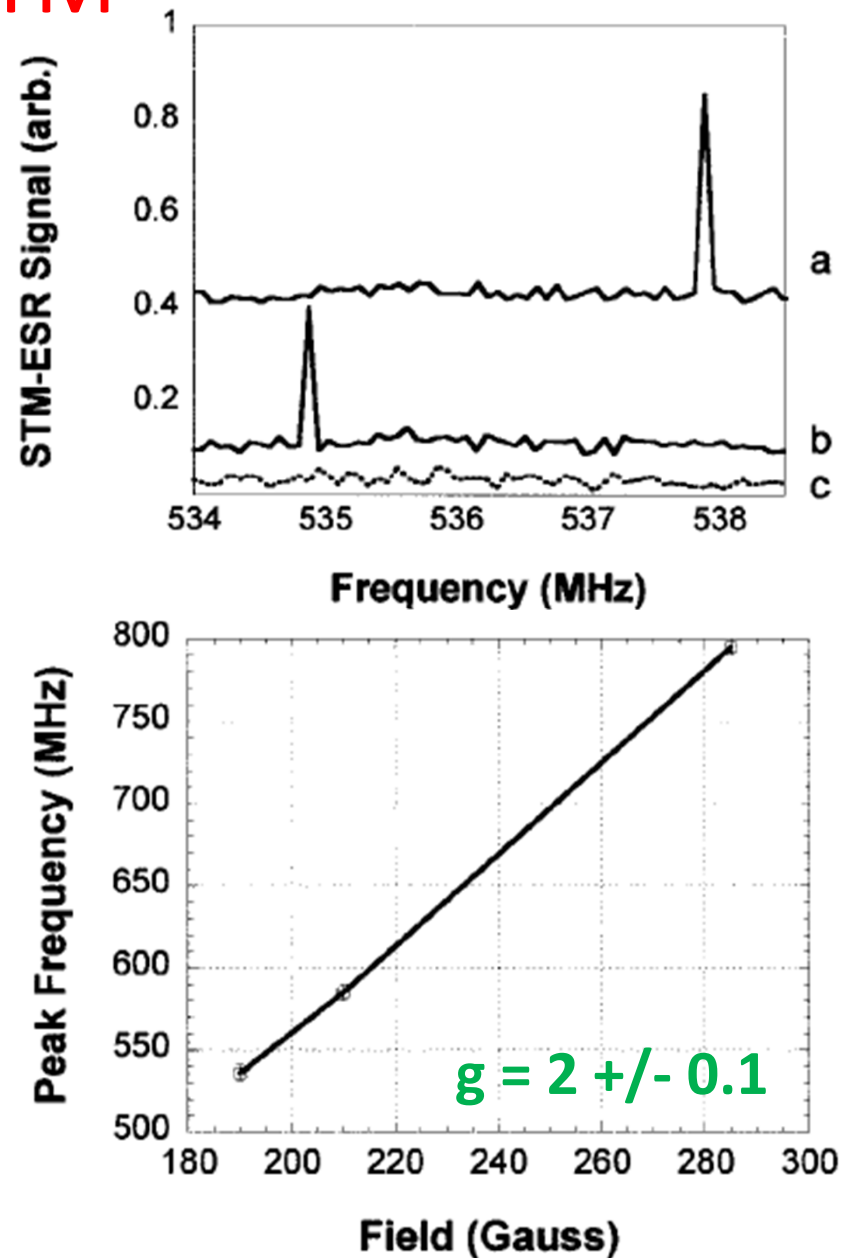

Electron Spin Resonance STM

History

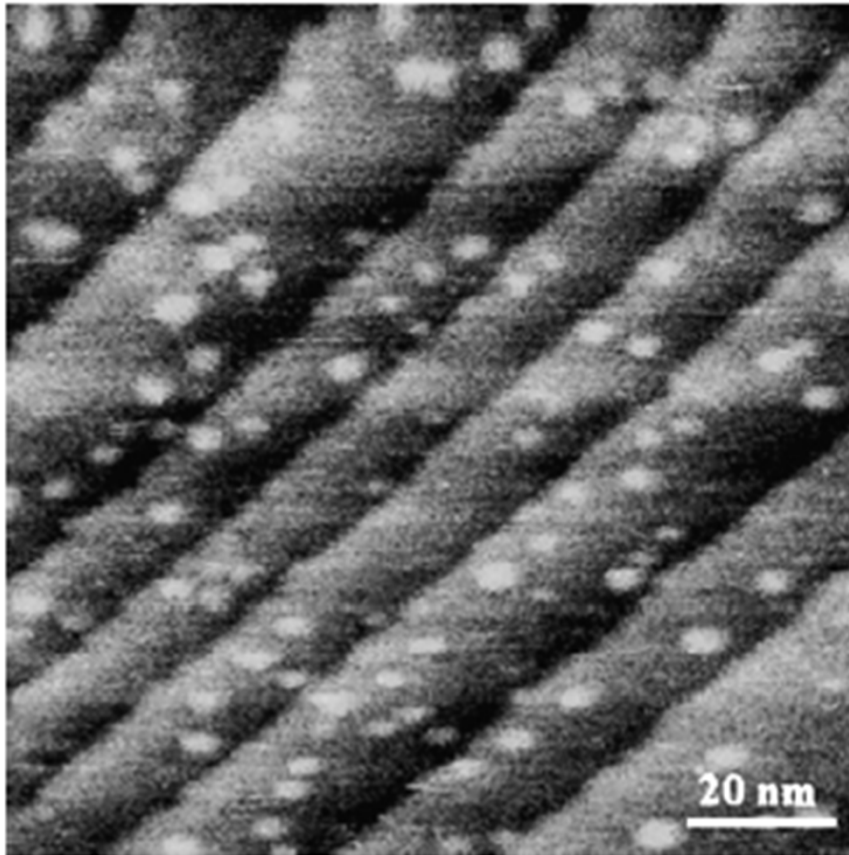

DPPH on Au(111)

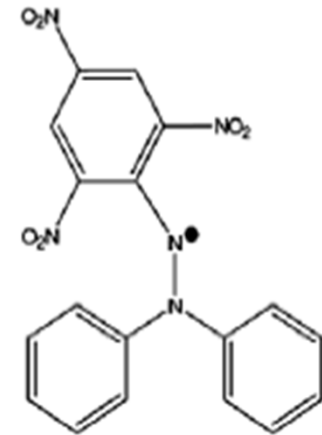
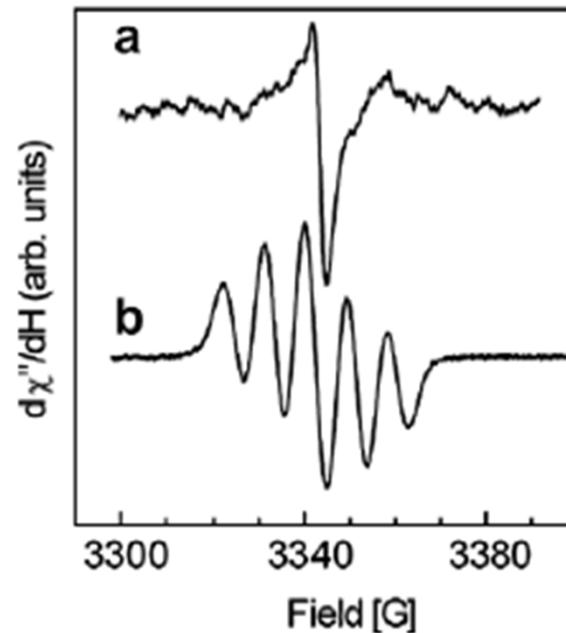

(a): Ultrathin film

(b): 0.1mM solution

Electron Spin Resonance STM

History

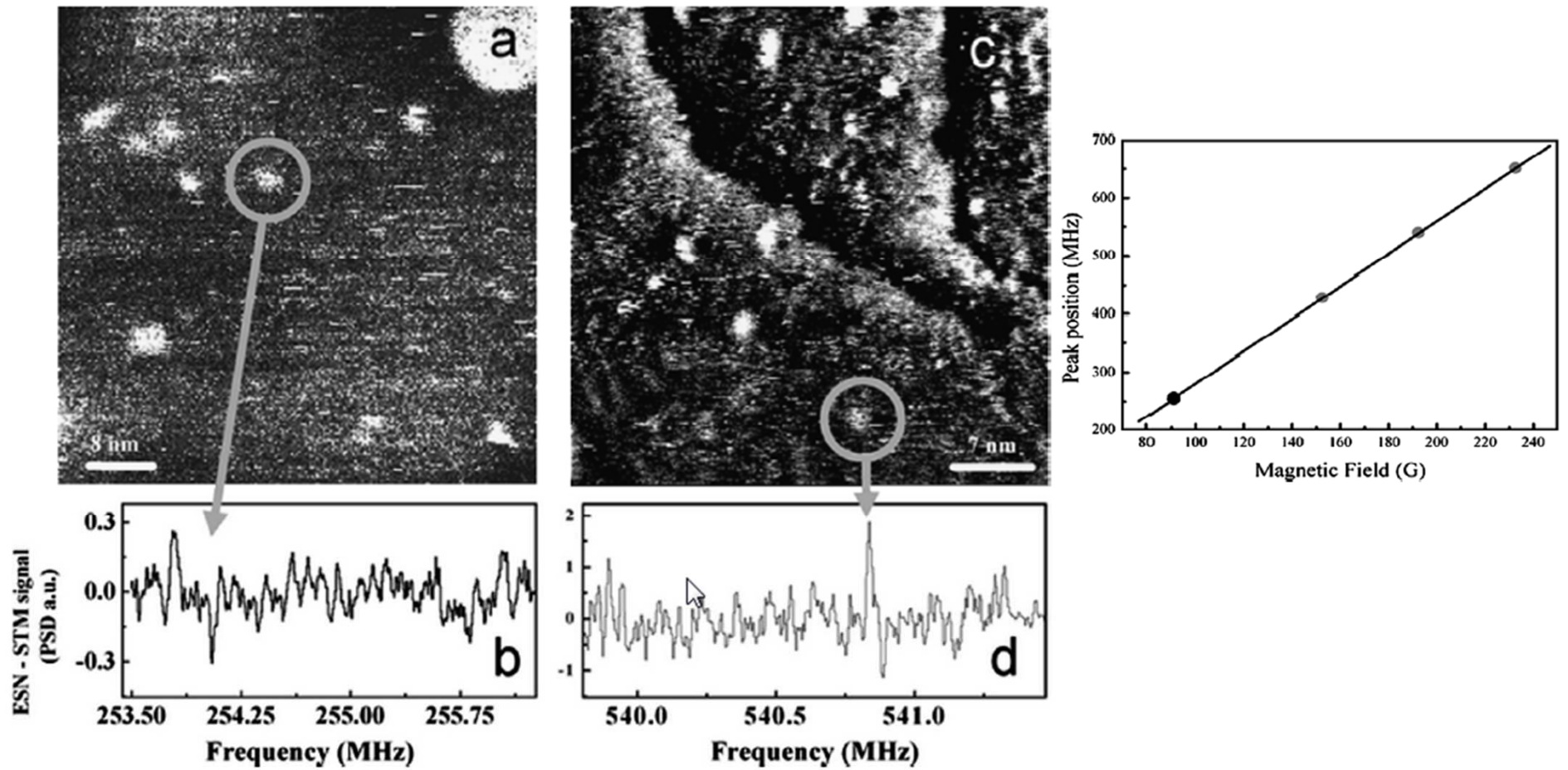

DPPH on Au(111)

Electron Spin Resonance STM

STM-ESR Mechanism:

Under investigation!

2 possible explanations:

(I) Spin-orbit interaction

Muzyrsky, *et al.* cond-matt/0201325 (2001)

Balatsky, *et al.* cond-matt/0112407 (2002)

(II) Temporal Spin-polarized current

Balatsky, *et al.* unpublished

Electron Spin Resonance STM

(I) Spin-orbit interaction

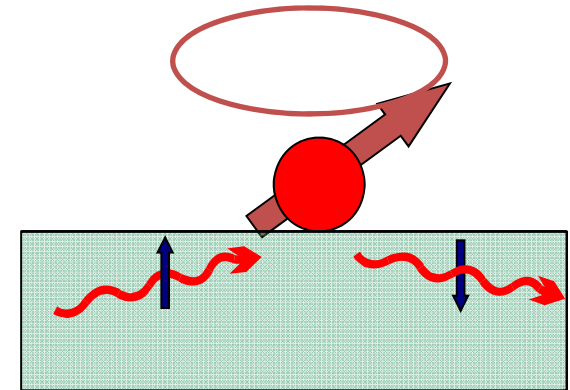

Energy of surface states (2D)

$$\varepsilon_{\alpha\beta}(k) = \frac{k^2}{2m^*} + g_{so} [k \times \sigma_{\alpha\beta}] \cdot \hat{n}$$

Hamiltonian with local spin

$$H = H_0 + JS \cdot \sigma$$

Correction to the LDOS near Fermi level

$$\frac{\delta N}{N} = g_{so} J \frac{dN}{dE} J_0^2(k_F r) [k_0 \times S] \cdot \hat{n}$$

$$\text{Power spectrum} \quad \frac{\langle I_{\omega}^2 \rangle}{2eI_0} = \frac{4\gamma^2}{(\omega - \omega_L)^2 + \gamma^2}$$

γ : Measurement-induced spin dephasing,
Environmental dephasing neglected

**Shortcoming: No strong spin-orbit interaction
in experiment (BDPA on HOPG)!**

Electron Spin Resonance STM

(II) Temporal Spin-polarized current

Tunneling electron per procession cycle

$$\begin{aligned} \frac{I}{e} T &= \frac{I}{e} \frac{2\pi}{\omega_L} = 2\pi \frac{mI}{Be^2} \\ &= 2\pi \frac{(0.9 \times 10^{-30}) \times 10^{-9}}{10^{-2} \times (1.6 \times 10^{-19})^2} \\ &= 22 \end{aligned}$$

Spin dependent tunneling matrix

$$\Gamma = \Gamma_0 \exp \left[- \sqrt{\frac{\Phi - JS(t)\hat{\sigma}}{\Phi_0}} \right]$$

Power spectrum

$$\frac{\overline{\langle I_{\omega}^2 \rangle}}{\langle I_{shot}^2(\omega) \rangle} = \left(\sinh \left[\frac{JS}{2\Phi} \sqrt{\frac{\Phi}{\Phi_0}} \right] \right)^2 \frac{\gamma / \tau_e}{(\omega - \omega_L)^2 + \gamma^2} \approx 2 - 4$$

γ : Measurement-induced spin dephasing,
Environmental dephasing neglected

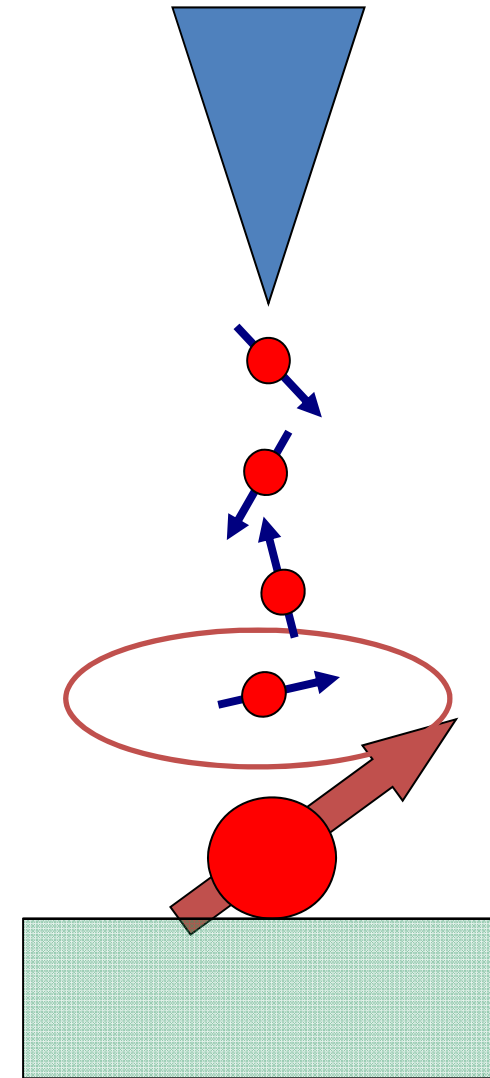

Electron Spin Resonance STM

A new method

PRL 113, 133001 (2014)

PHYSICAL REVIEW LETTERS

week ending
26 SEPTEMBER 2014

Radio Frequency Scanning Tunneling Spectroscopy for Single-Molecule Spin Resonance

Stefan Müllegger,^{1,*} Stefano Tebi,¹ Amal K. Das,^{1,†} Wolfgang Schöfberger,² Felix Faschinger,² and Reinhold Koch¹

¹*Institute of Semiconductor and Solid State Physics, Johannes Kepler University Linz, 4040 Linz, Austria*

²*Institute of Organic Chemistry, Johannes Kepler University Linz, 4040 Linz, Austria*

(Received 3 July 2014; published 25 September 2014)

We probe nuclear and electron spins in a single molecule even beyond the electromagnetic dipole selection rules, at readily accessible magnetic fields (few mT) and temperatures (5 K) by resonant radio-frequency current from a scanning tunneling microscope. We achieve subnanometer spatial resolution combined with single-spin sensitivity, representing a 10 orders of magnitude improvement compared to existing magnetic resonance techniques. We demonstrate the successful resonant spectroscopy of the complete manifold of nuclear and electronic magnetic transitions of up to $\Delta I_z = \pm 3$ and $\Delta J_z = \pm 12$ of single quantum spins in a single molecule. Our method of resonant radio-frequency scanning tunneling spectroscopy offers, atom-by-atom, unprecedented analytical power and spin control with an impact on diverse fields of nanoscience and nanotechnology.

✉

Electron Spin Resonance STM

A new method

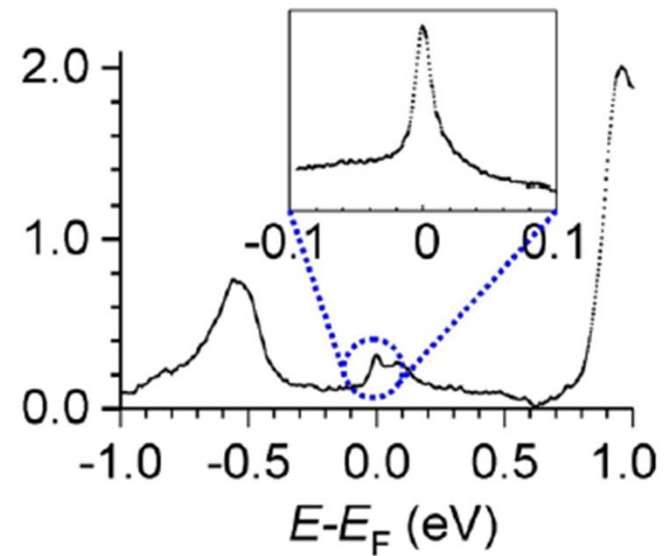
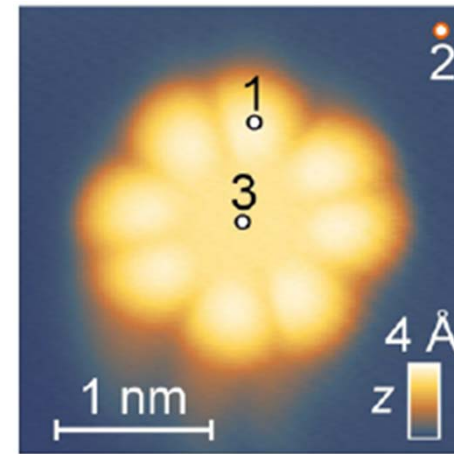
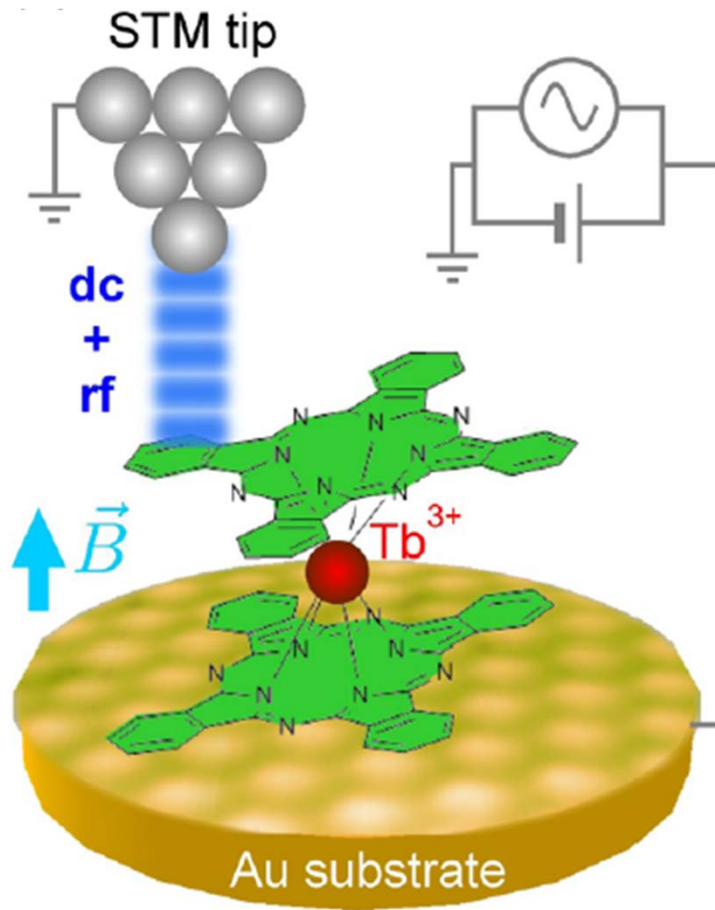

Electron Spin Resonance STM

A new method

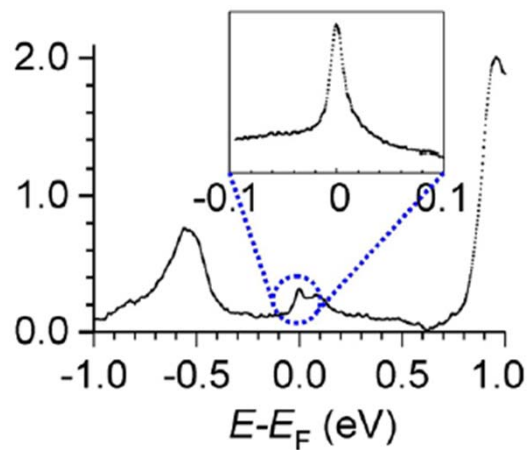

(a) Ligand, 2.5 mT, +0.9 V

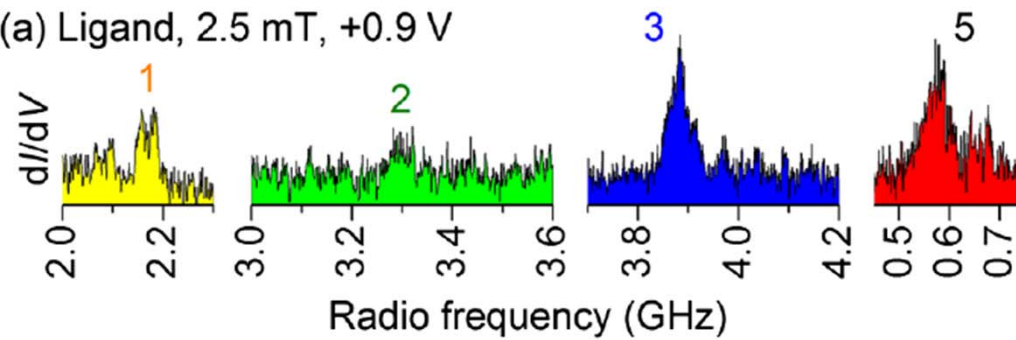

(b) Ligand, 16 mT, +0.9 V

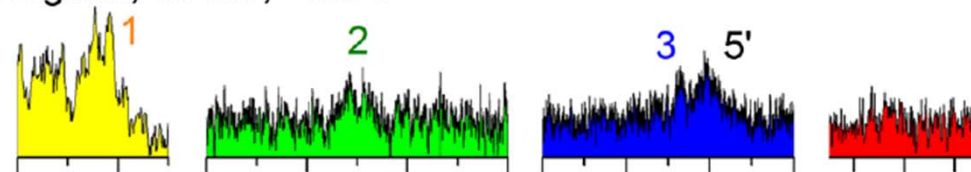

(c) Bare gold, 2.5 mT, +0.9 V

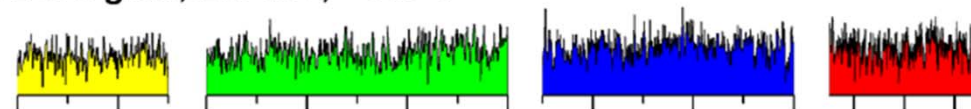

(d) Ligand, 2.5 mT, +0.7 V non-MO

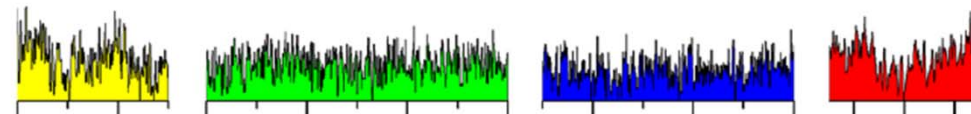

(e) Center, 2.5 mT, +0.9 V

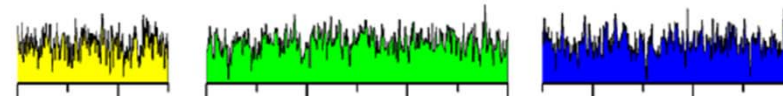

Electron Spin Resonance STM

A new method

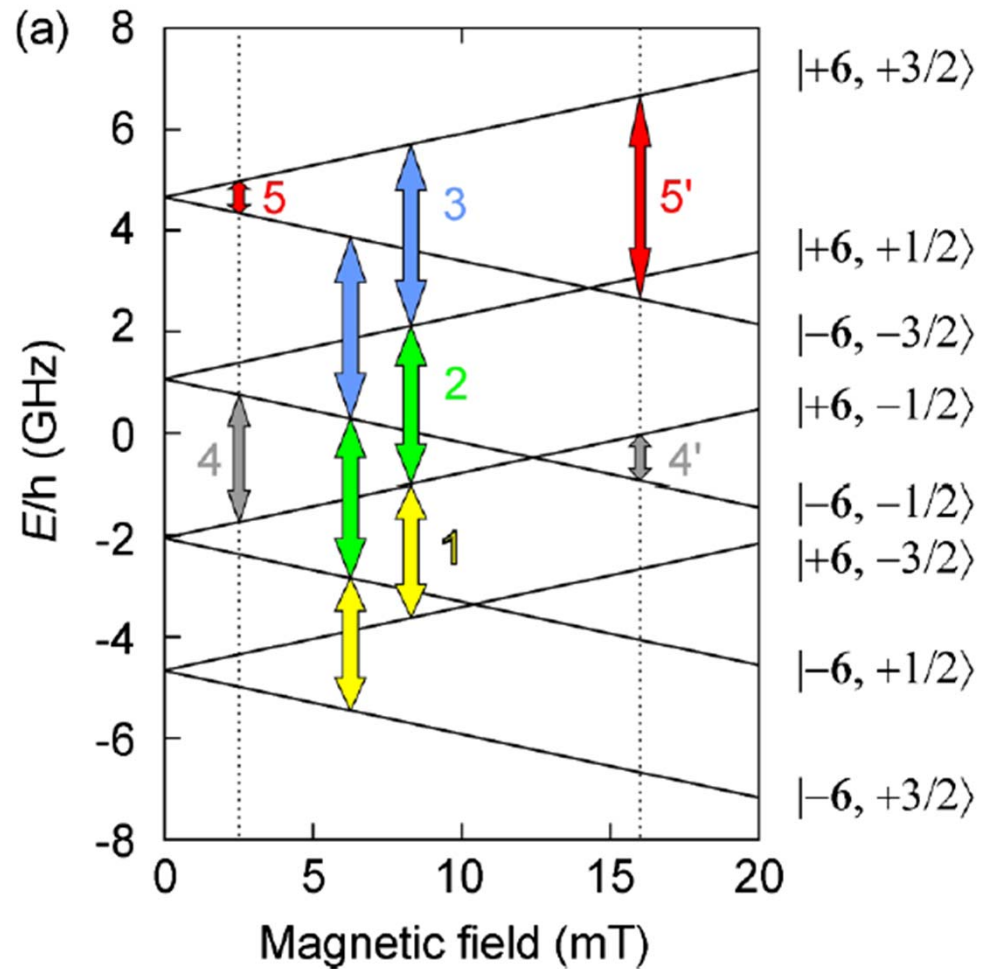

Electron Spin Resonance STM

A new method

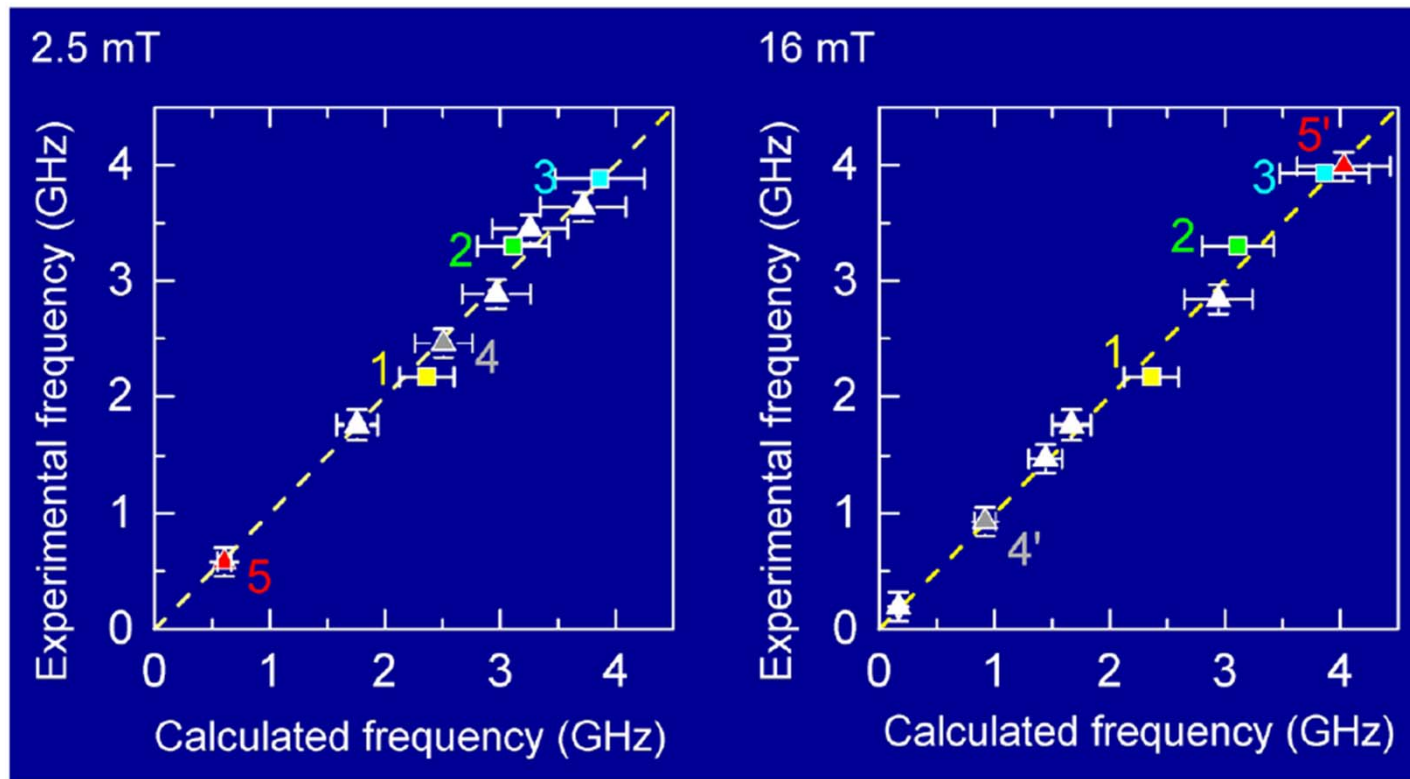

Electron Spin Resonance STM

Goals:

STM-ESR mechanism

- Current and voltage dependence
- Spatial dependence
- Temperature dependence
- Tip dependence

Spin-decoherence

- Measurement-induced
- Environmental

Spin-coupling/entanglement

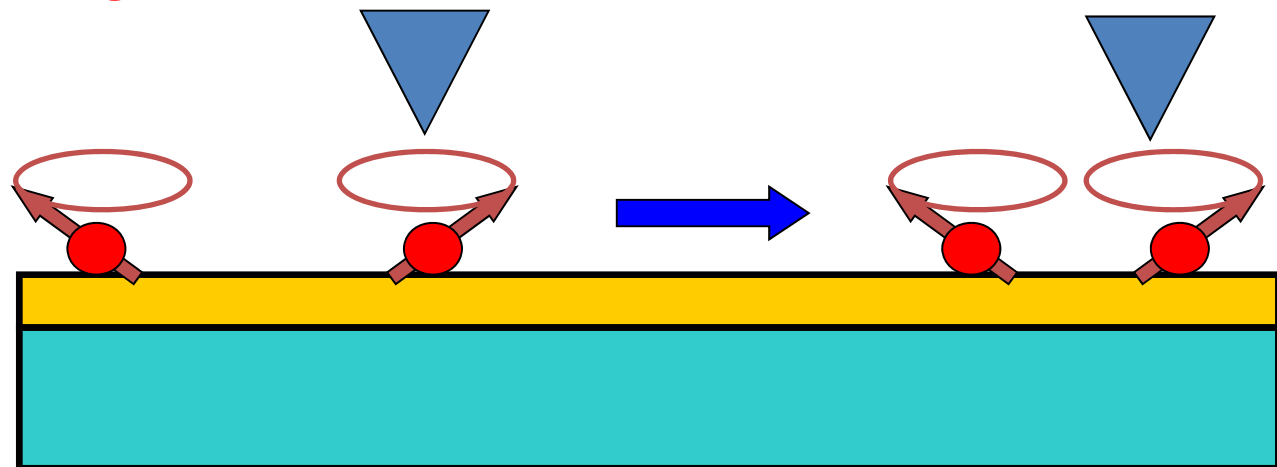

Magnetic Resonance Force Microscope

1991: Basic principle proposed

Applied Physics Letters

Noninductive detection of single-proton magnetic resonance

J. A. Sidles

School of Medicine, Department of Orthopaedics RK-10, University of Washington, Seattle, Washington 98195

(Received 23 January 1991; accepted for publication 22 April 1991)

The presence of nuclear magnetic resonance can be detected noninductively by coupling the nuclear spin to the motion of a mechanical oscillator. The coupling is obtained by applying a large-gradient magnetic field, which exerts a mechanical force on the particle by virtue of its magnetic moment. The coupling increases in strength as the oscillator mass is decreased and the gradient length scale is made shorter. Oscillator-based detection is thus only marginally effective for macroscopic samples, but can be quite effective for single protons interacting with a micron-scale oscillator. This letter describes the physics of devices in which single-nucleon magnetic resonance is detected by monitoring the excitation of a mechanical oscillator.

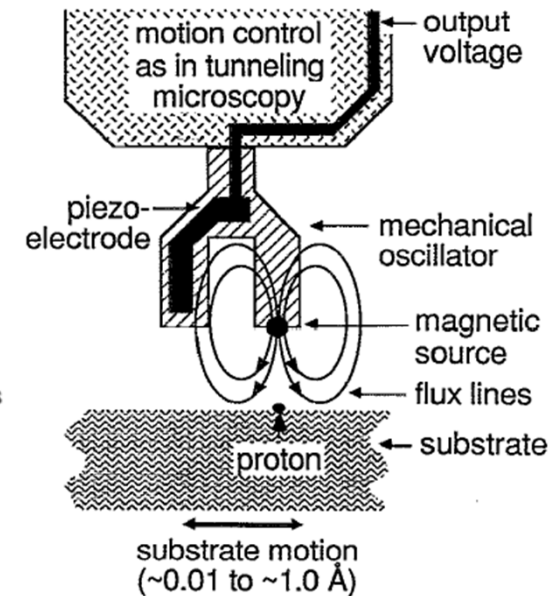

Magnetic Resonance Force Microscope

1993: First MRFM image obtained

Applied Physics Letters

First images from a magnetic resonance force microscope

O. Züger and D. Rugar^{a)}

IBM Research Division, Almaden Research Center, 650 Harry Road, San Jose, California 95120

(Received 26 July 1993; accepted for publication 2 September 1993)

We describe a new magnetic resonance imaging technique based on the measurement of magnetic force acting between a magnetic tip and the resonantly excited spins in the sample. Magnetic resonance force maps of the sample are formed by scanning the tip with respect to the sample while measuring the angstrom-scale vibration of a microcantilever holding the sample. Real-space spin density information can be recovered from the force maps by using a simple image reconstruction technique. The technique was demonstrated for electron spin resonance in micrometer-size particles of diphenylpicrylhydrazil. Using a tip that generates a field gradient of $4.3 \text{ G}/\mu\text{m}$, a lateral resolution of $5 \mu\text{m}$, and an axial resolution of $1 \mu\text{m}$ was achieved.

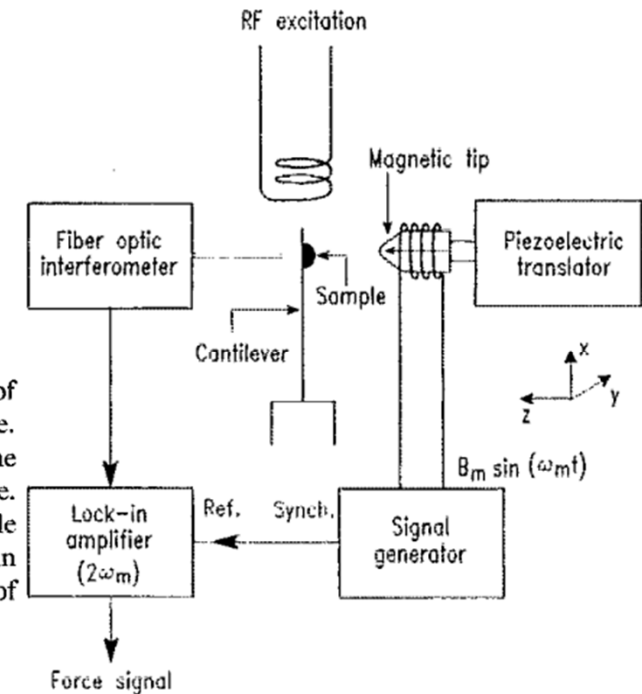

Magnetic Resonance Force Microscope

1993: First MRFM image obtained

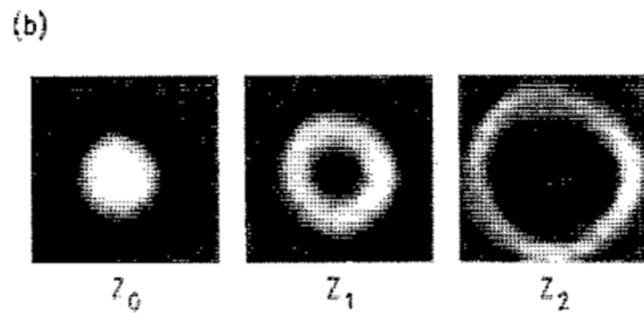
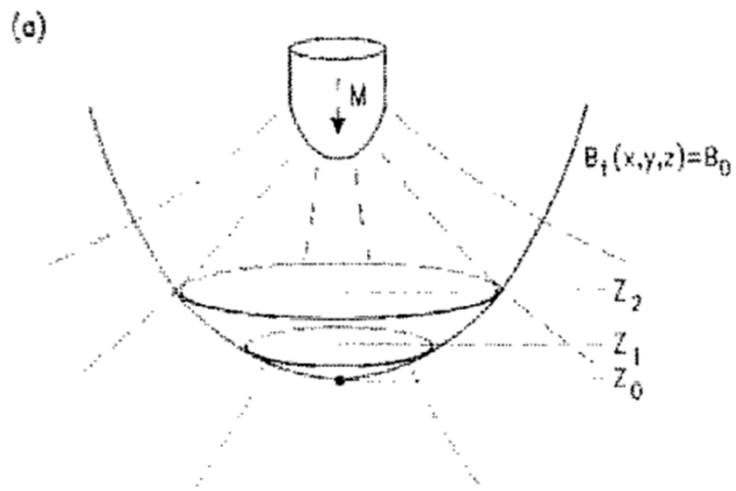

(b) Force map



(c) Reconstructed image



50 μm

Magnetic Resonance Force Microscope

1993: First MRFM image obtained

Spatial Resolution: 10 μ m

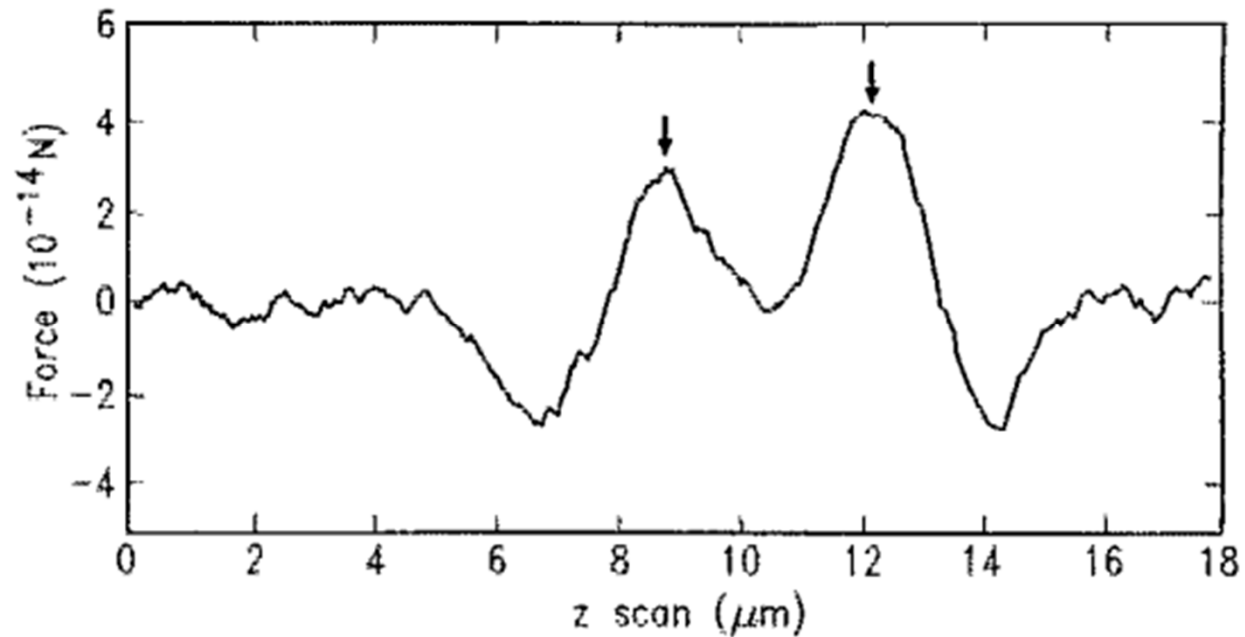

Magnetic Resonance Force Microscope

2004: Detection of single electron spin

Nature

Single spin detection by magnetic resonance force microscopy

D. Rugar, R. Budakian, H. J. Mamin & B. W. Chui

IBM Research Division, Almaden Research Center, 650 Harry Rd, San Jose, California 95120, USA

Magnetic resonance imaging (MRI) is well known as a powerful technique for visualizing subsurface structures with three-dimensional spatial resolution. Pushing the resolution below $1\ \mu\text{m}$ remains a major challenge, however, owing to the sensitivity limitations of conventional inductive detection techniques. Currently, the smallest volume elements in an image must contain at least 10^{12} nuclear spins for MRI-based microscopy¹, or 10^7

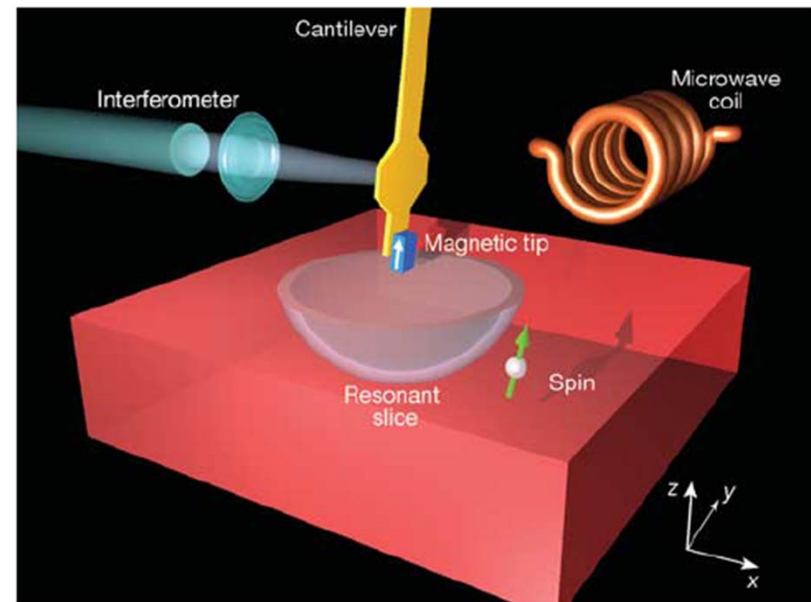

Magnetic Resonance Force Microscope

2004: Detection of single electron spin

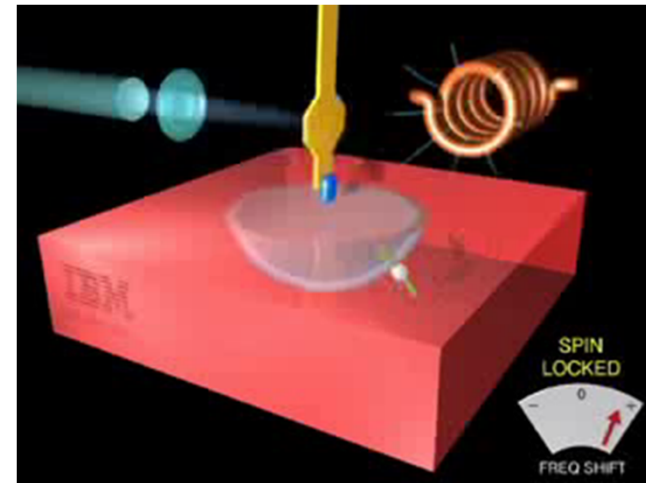
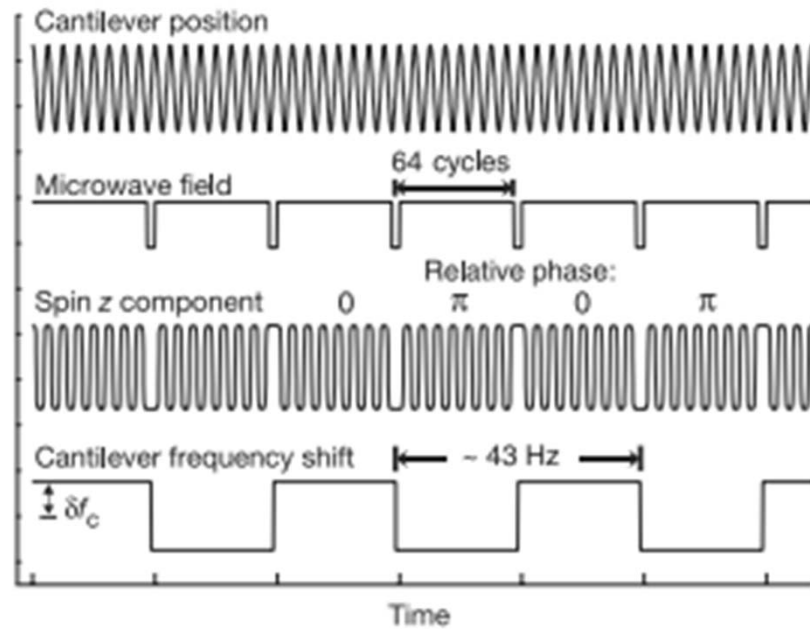

Magnetic Resonance Force Microscope

2004: Detection of single electron spin

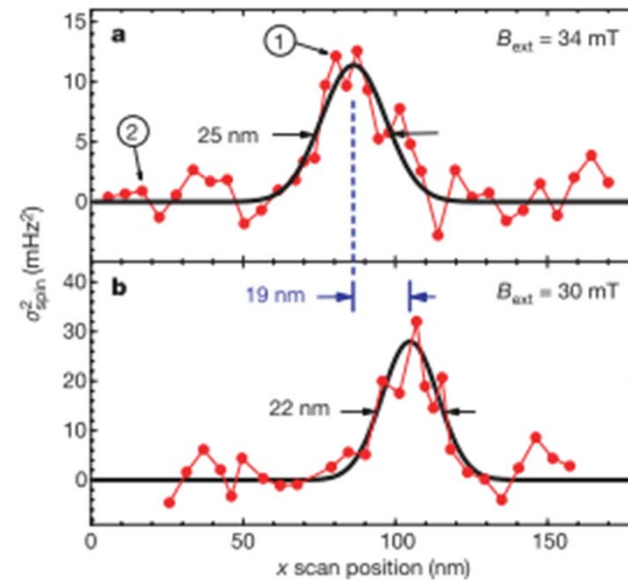
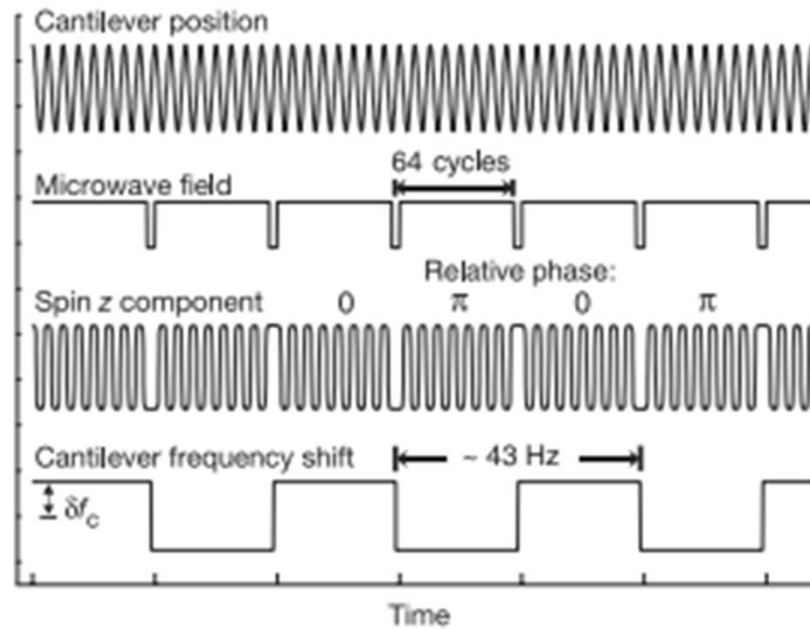

Magnetic Resonance Force Microscope

2009: 3D imaging resolution < 10nm

PNAS

Nanoscale magnetic resonance imaging

C. L. Degen^a, M. Poggio^{a,b}, H. J. Mamin^a, C. T. Rettner^a, and D. Rugar^{a,1}

^aIBM Research Division, Almaden Research Center, 650 Harry Road, San Jose, CA 95120; and ^bCenter for Probing the Nanoscale, Stanford University, 476 Lomita Mall, Stanford, CA 94305

Communicated by Stuart S. P. Parkin, IBM Almaden Research Center, San Jose, CA, December 1, 2008 (received for review August 21, 2008)

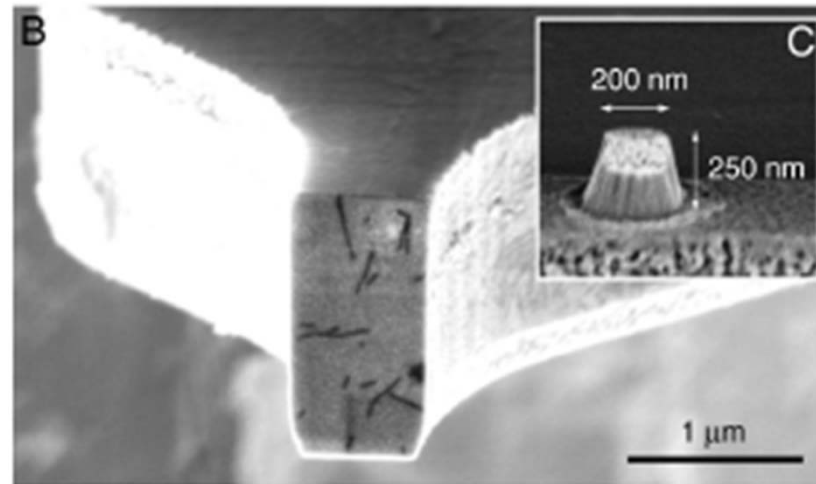
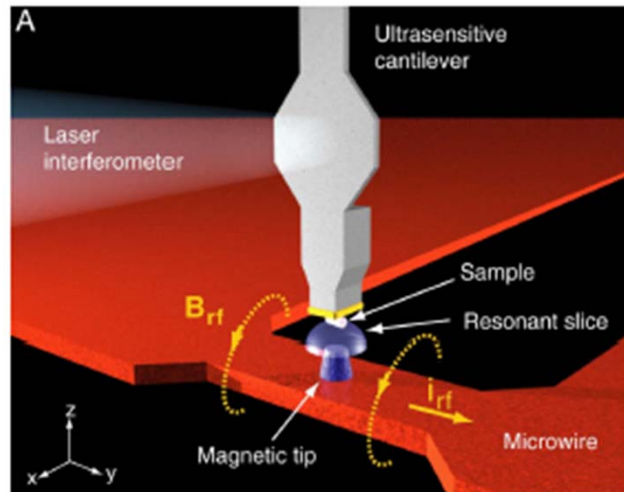

Magnetic Resonance Force Microscope

2009: 3D imaging resolution < 10nm

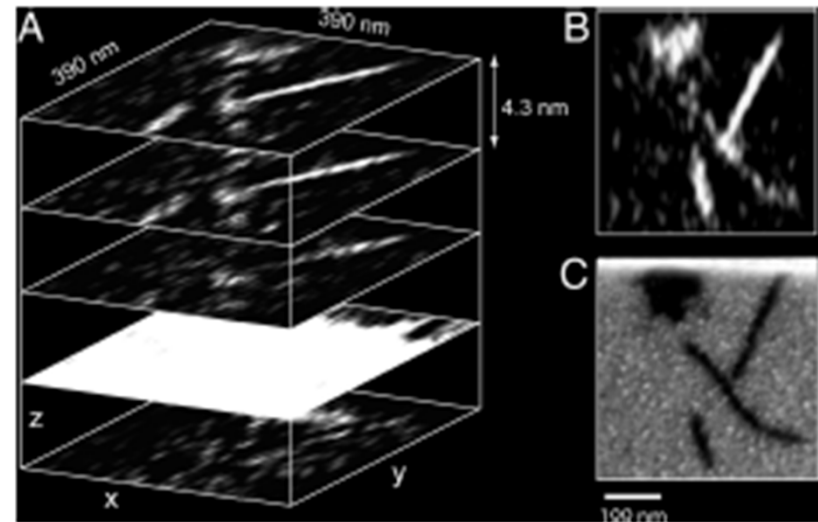
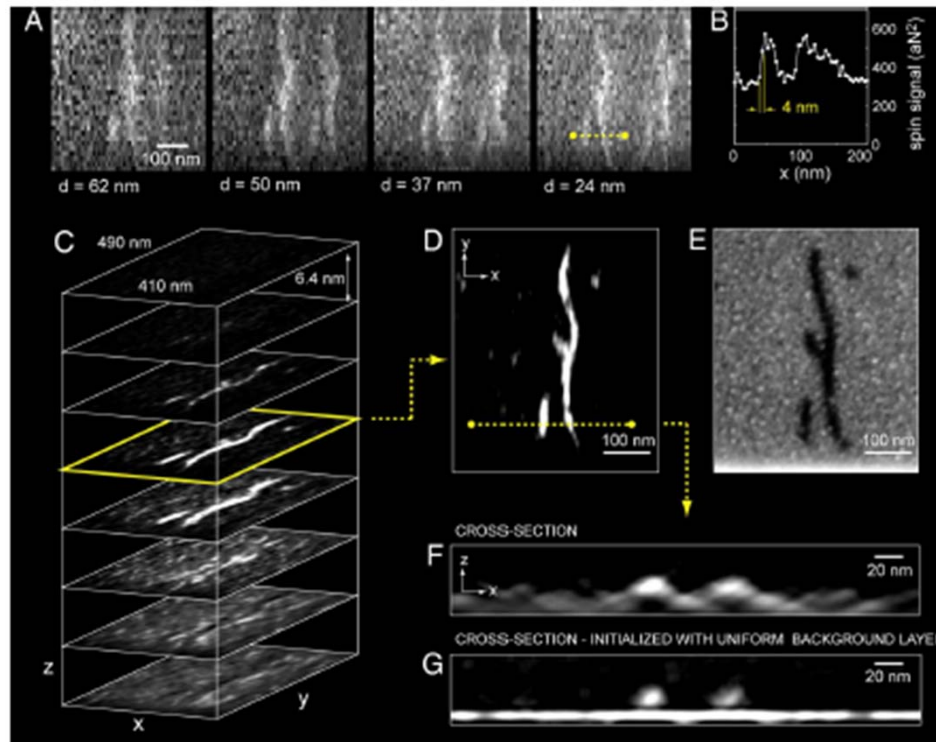

Electron Spin Resonance STM

Road Map

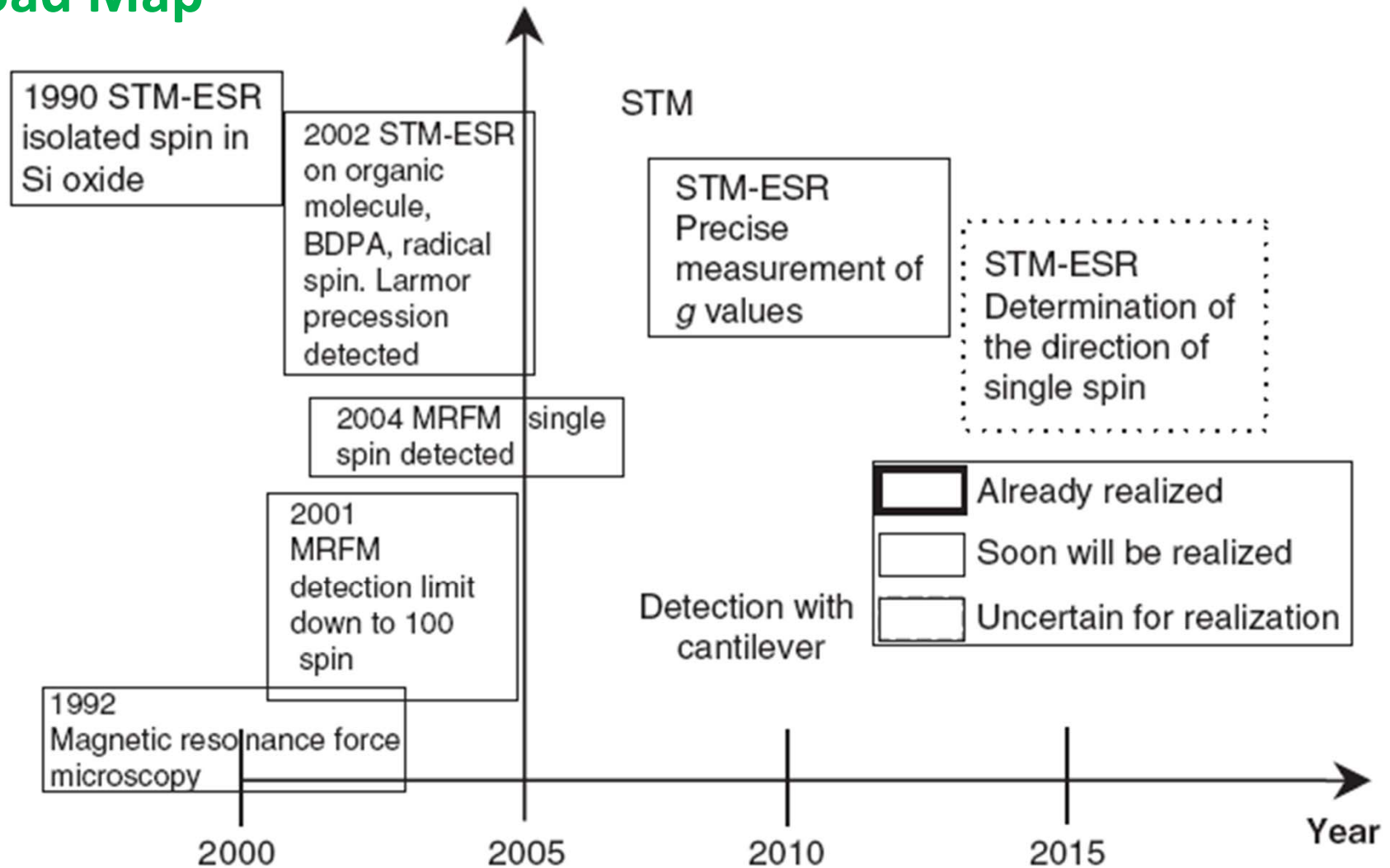

by Ken Nakajima and Tadahiro Komeda